

# Rugged Tablet

## MDT-805

8 Inch 5G Rugged Android Tablet / In-Vehicle Terminal

# User Manual

Version 1.0



## Revision History

Version	Release Time	Description
1.0	202512	Initial Release

## Copyright

Copyright © PaceBlade. All Rights Reserved. This document contains proprietary information protected by copyright.

## About This Manual

This user manual provides the general information and installation instructions for the product. The manual is meant for the experienced users and integrators with hardware knowledge of personal computers. If you are not sure about any description in this manual, consult your vendor before further handling.

We recommend that you keep one copy of this manual for the quick reference for any necessary maintenance in the future. Thank you for choosing PaceBlade.

## Safety Precautions

Please charge and discharge the device as one cycle at room temperature when devices are stored for more than 3 months or above.

Do not attempt to repair, customize, or disassemble the device without the appropriate knowledge and pre-cautions may lead to dangerous situations with chance on damaging the product.

Do not use in extreme conditions such as high and low temperatures. It may damage the battery and impact the product life time. please avoid long-time exposure to sunlight.

# Table of Contents

Chapter 1: Introduction .....	4
1.1 Product Highlights .....	4
1.2 Connect different cradles .....	7
1.2.1 MDT-805 Cradle .....	7
1.2.2 MDT-805 Cradle .....	8
1.2.3 MDT-805 Metal Bracket .....	11
1.2.4 MDT-805 LAN Metal Bracket .....	13
1.3 Accessories .....	20
1.3.1 Cradles .....	20
1.3.2 Expansion Modules .....	21
1.3.3 Chargers .....	22
1.3.4 Other Accessories .....	22
Chapter 2: Getting Started .....	23
2.1 Power On/Off and Sleep/Wake .....	24
2.2 Installing Micro SD and SIM Card .....	25
2.3 Charging the Battery .....	25
2.4 Charging with the vehicle power supply .....	26
Chapter 3: Hand strap and shoulder strap mode .....	27
3.1 Hand strap .....	27
Chapter 4: Cradle Using Instruction .....	29
4.1 To be vehicle cradle .....	29
4.2 To be a desktop dock station .....	30
Chapter 5: Using Hardware Interface .....	32
5.1 Using Serial Port .....	32
5.2 Using GPIO (It only works on CRD805.) .....	33
5.3 Using NFC Function .....	33
5.4 Using eSIM function .....	34
Chapter 6: Specifications .....	37
Chapter 7: Software Support .....	37
Radio Parameters .....	38
Chapter 8: Safety and regulatory compliance .....	40

# Chapter 1: Introduction

## 1.1 Product Highlights

- MediaTek 64-bit Octa-core processor
  - 2X Arm Cortex-A76 up to 2.2GHz
  - 6X Arm Cortex-A55 up to 2.0GHz
- Android 14 Operation System
- Comply with IP67 rating
- WIFI, Bluetooth, 5G, GNSS and 8000mAh rechargeable battery supported
- 8Inch MIPI LCD 1280x800 resolution, multi-point capacitive touch
- 1.2m / 4 ft. to drop per MIL-STD-810H
- 2-in-1 cradle which can be used as a vehicle cradle or desktop station

## 1.1.1 Parts of the Device

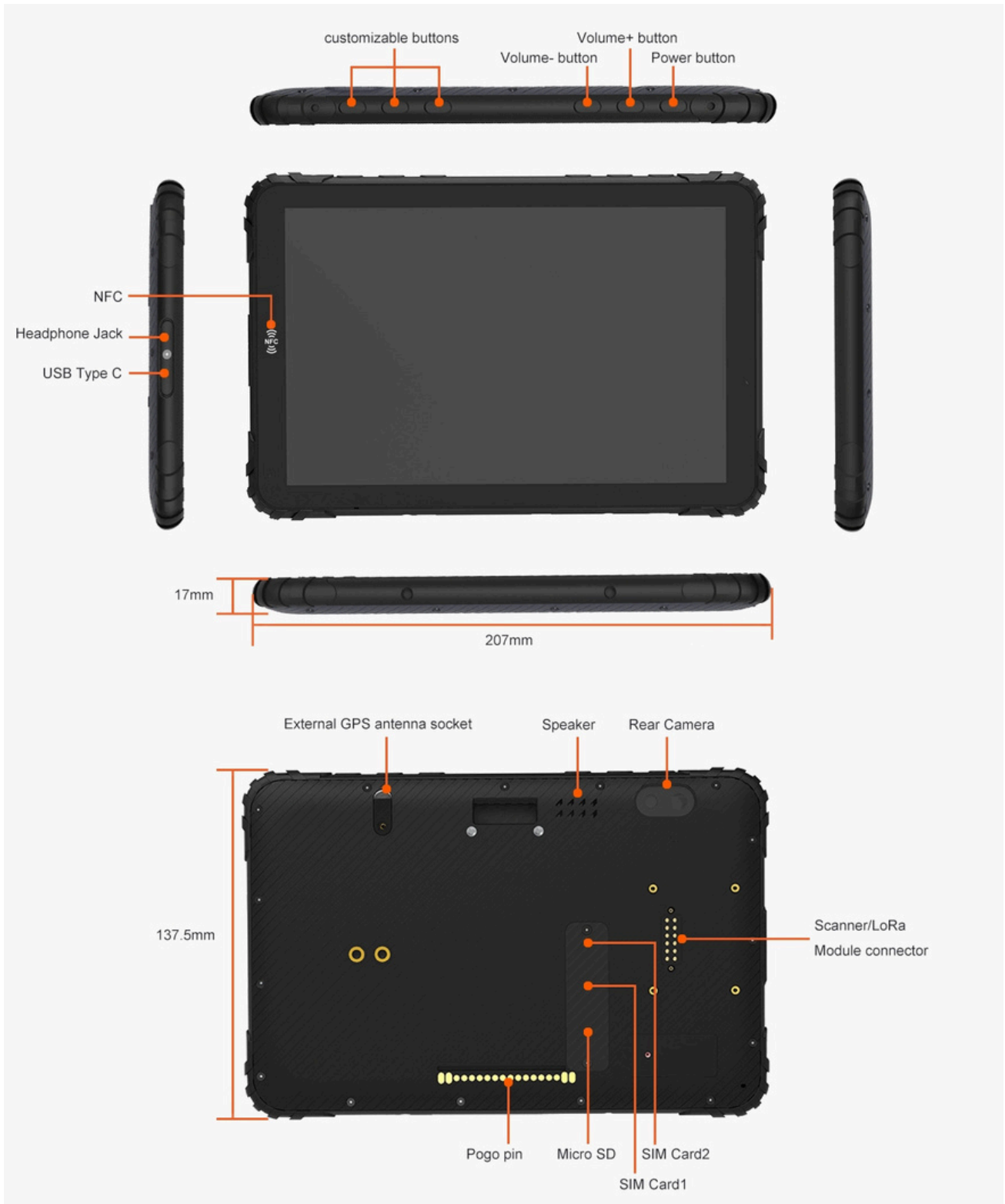

## Summary of functions achieved by cradles and cables combination

Links	Cradles	Cables	Features
<a href="#">CRD805</a>		CAB-801-2RS232 CAB-EX-RS232 CAB-BMW-BASIC CAB-EX-BASIC	<input type="checkbox"/> VCC /IGN DC12~32V input <input type="checkbox"/> 2× USB-A (OTG) <input type="checkbox"/> 1× USB-C (Charge) <input type="checkbox"/> 1× RJ45(Ethernet) <input type="checkbox"/> 2× RS232 <input type="checkbox"/> 1× RS485 <input type="checkbox"/> 4× GPIO <input type="checkbox"/> 4× Camera (Video input) <input type="checkbox"/> 4× Trigger
<a href="#">FFC-MDT-801 (TYPE-A)</a>		CAB-MD-FULL CAB-EX-FULL CAB-EX-HUB Video cable	<input type="checkbox"/> VCC /IGN DC12~32V input <input type="checkbox"/> 2× USB-A (OTG) <input type="checkbox"/> 1× USB-C (Charge) <input type="checkbox"/> 1× RJ45(Ethernet) <input type="checkbox"/> 2× RS232 <input type="checkbox"/> 1× RS485 <input type="checkbox"/> 4× Camera (Video input)(With Camera Hub) <input type="checkbox"/> 4× Trigger
<a href="#">FFC-MDT-801 (TYPE-B)</a>		CAB-801-BASIC CAB-BMW-BASIC CAB-EX-BASIC	<input type="checkbox"/> VCC /IGN DC12~32V input <input type="checkbox"/> 2× USB-A (OTG) <input type="checkbox"/> 1× USB-C (Charge) <input type="checkbox"/> 1× RJ45(Ethernet) <input type="checkbox"/> 1× RS232
<a href="#">BC-MDT-801 (TYPE-C)</a>		CAB-OTG-BASIC CAB-EX-BASIC	<input type="checkbox"/> VCC /IGN DC12~32V input <input type="checkbox"/> 3× USB-A (OTG) <input type="checkbox"/> 1× USB-C (Charge) <input type="checkbox"/> 1× RJ45(Ethernet) <input type="checkbox"/> 1× RS232
<a href="#">CRD-801-M12</a>		CAB-801-BASIC CAB-BMW-BASIC CAB-EX-BASIC M12 to RJ45 female adapter cable	<input type="checkbox"/> VCC /IGN DC12~32V input <input type="checkbox"/> 2× USB-A (OTG) <input type="checkbox"/> 1× USB-C (Charge) <input type="checkbox"/> 1× M12 connector (Ethernet) <input type="checkbox"/> 1× RS232
<a href="#">BKT-801</a>		BKT801-BAS-02 (Waterproof connector)	<input type="checkbox"/> VCC /IGN DC12~32V input <input type="checkbox"/> 1× RS232
<a href="#">BKT-801-BMW</a>		CAB-BMW-BASIC CAB-EX-BASIC	<input type="checkbox"/> VCC /IGN DC12~32V input <input type="checkbox"/> 1× RS232
<a href="#">BKT-801-OTG</a>		CAB-EX-BASIC One USB-A OTG female connector on the cradle cable.	<input type="checkbox"/> VCC /IGN DC12~32V input <input type="checkbox"/> 1× RS232 <input type="checkbox"/> 1× USB-A (OTG)
<a href="#">BKT-801-M12</a>		CAB-LAN-01 CAB-BMW-BASIC CAB-EX-BASIC M12 to RJ45 female adapter cable.	<input type="checkbox"/> VCC /IGN DC12~32V input <input type="checkbox"/> 1× USB-C (Charge) <input type="checkbox"/> 1× M12 connector (Ethernet) <input type="checkbox"/> 1× RS232
<a href="#">BKT-801-BCR</a>		USB-C to C cable	<input type="checkbox"/> 1× USB-C (Charge) <input type="checkbox"/> 1× RJ45(Ethernet)(optional) <input type="checkbox"/> 1× 1D/2D Barcode Scanner

## 1.2 Connect different cradles

### 1.2.1 CRD805 Cradle

CRD805 - FULL cradle interface.

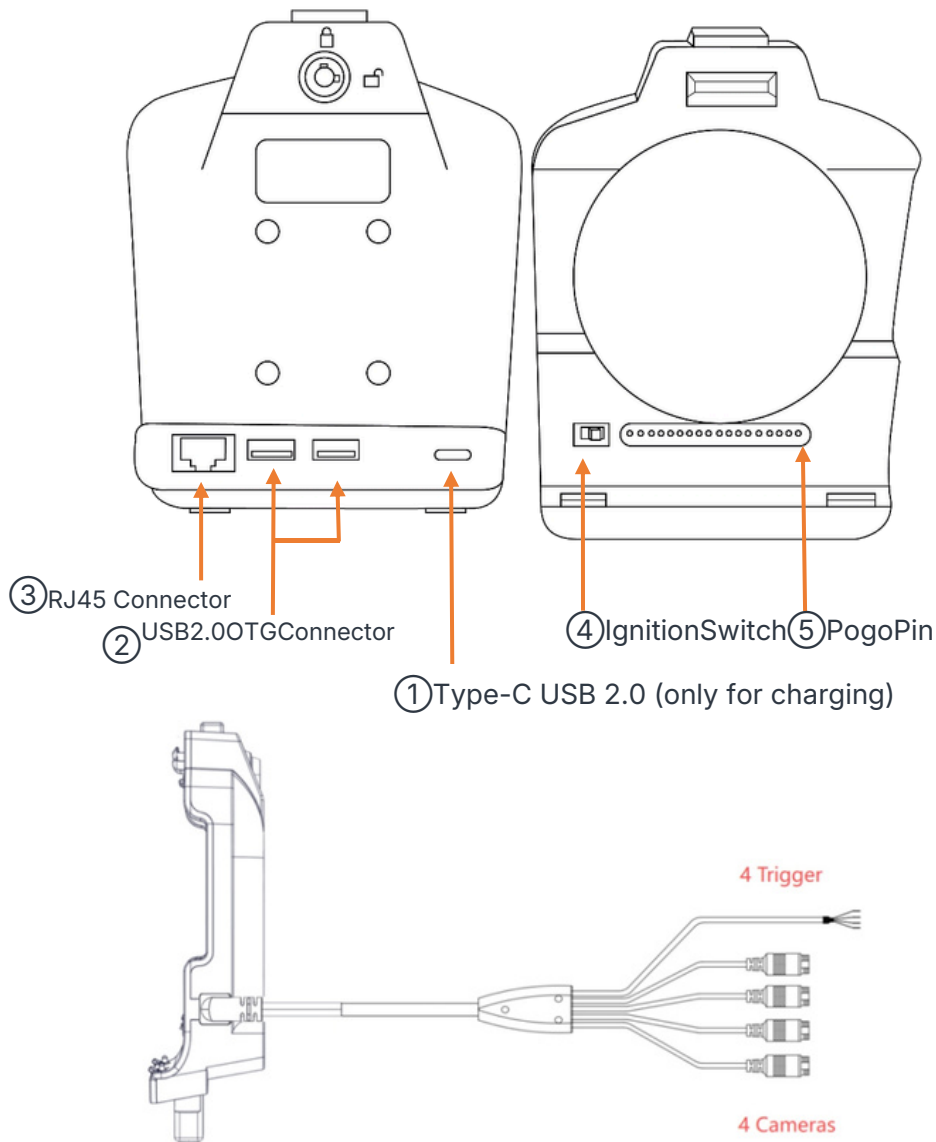

#### CRD805-FULL Cradle Features

- Vehicle Input: DC12V to 32V, ignition control with optional switch in the cradle.
- PD Fast-charging AC adapter or charge input 5V/3A, 9V/2A, 12V/2A with Type-C connector.
- USB 2.0 OTG Connector x 2
- RJ45 connector for Ethernet
- 4 channels camera (supported Analog, AHD720P and 1080P camera) and 4 Triggers.

**Note:** The system supports connecting multiple cameras, but all connected cameras must be of the same type.

- Ignition switch: the ignition switch is switched to the right side, charging is independent of ignition ON/OFF. If ignition switch is switched to the left side, charging is dependent of ignition ON.

### 1.2.1.1 CRD805-FULL cradle with GPIO and RS232/RS485 cables

It provides 4 GPIOs, 2 RS232s and 1 RS485.

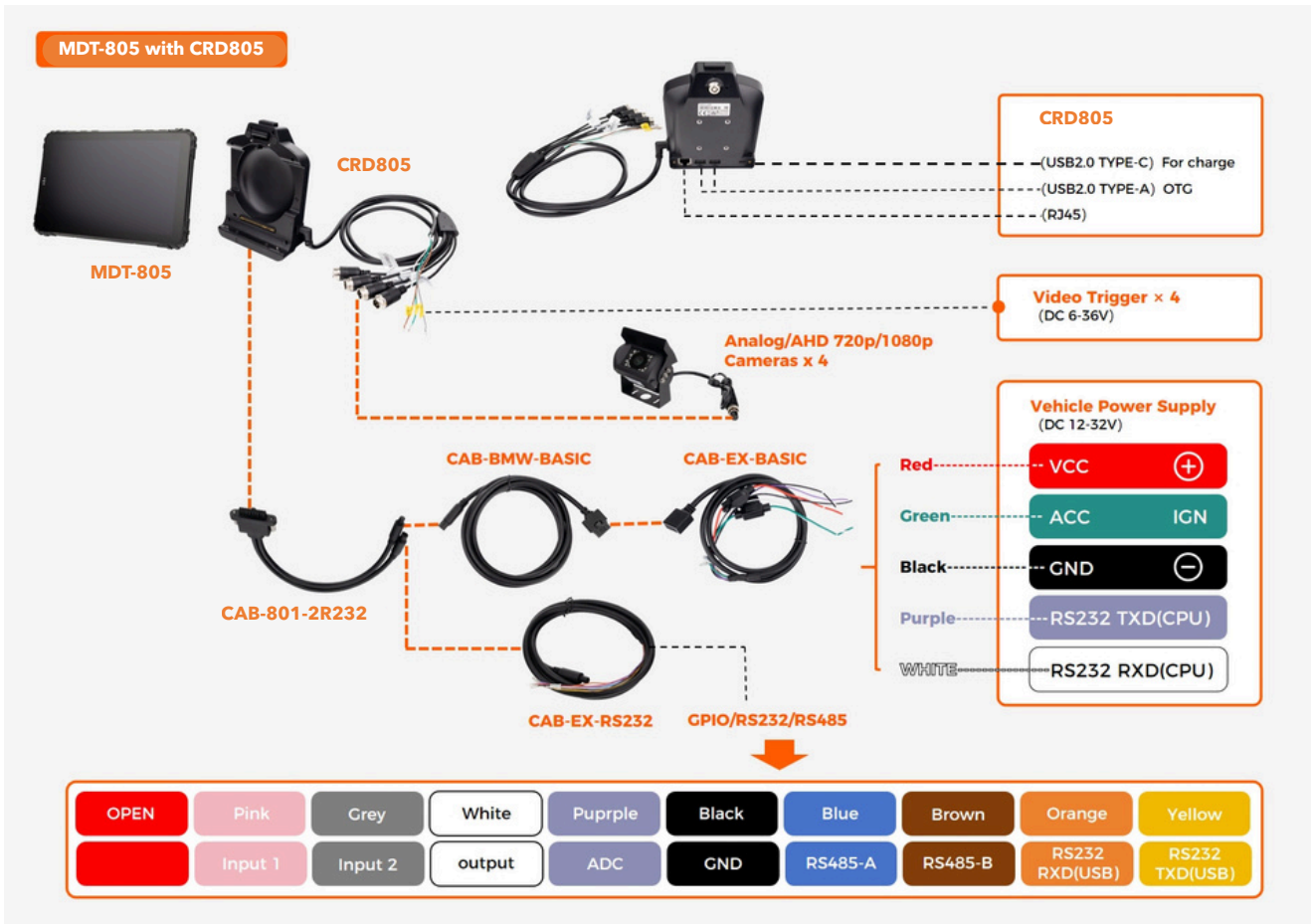

### 1.2.2 FFC-MDT-801 & BCL-801 Cradle

Full features cradle

Basic features cradle

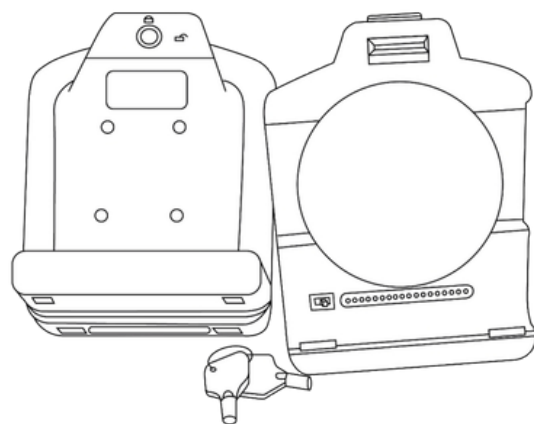
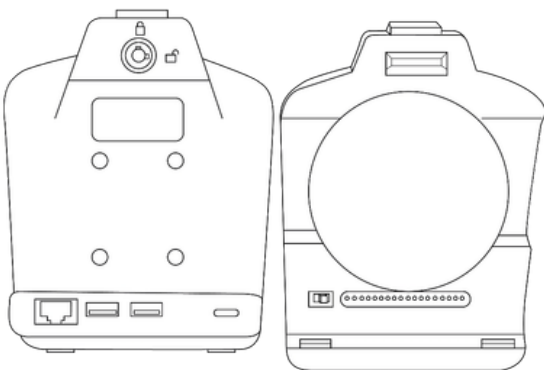

**FFC-MDT-801 - Full features Cradle**  
With RJ45, USBA OTG (USB2.0) USBC (For charging only)

**BCL-801 - BASIC Cradle**  
Without RJ45, USBA OTG and USBC charge function

### 1.2.2.1 FFC-MDT-801 with full features cable

It provides 2 RS232 and 1 RS485.

Connect to the camera hub to provide video input function.

not supported video input and GPIO.

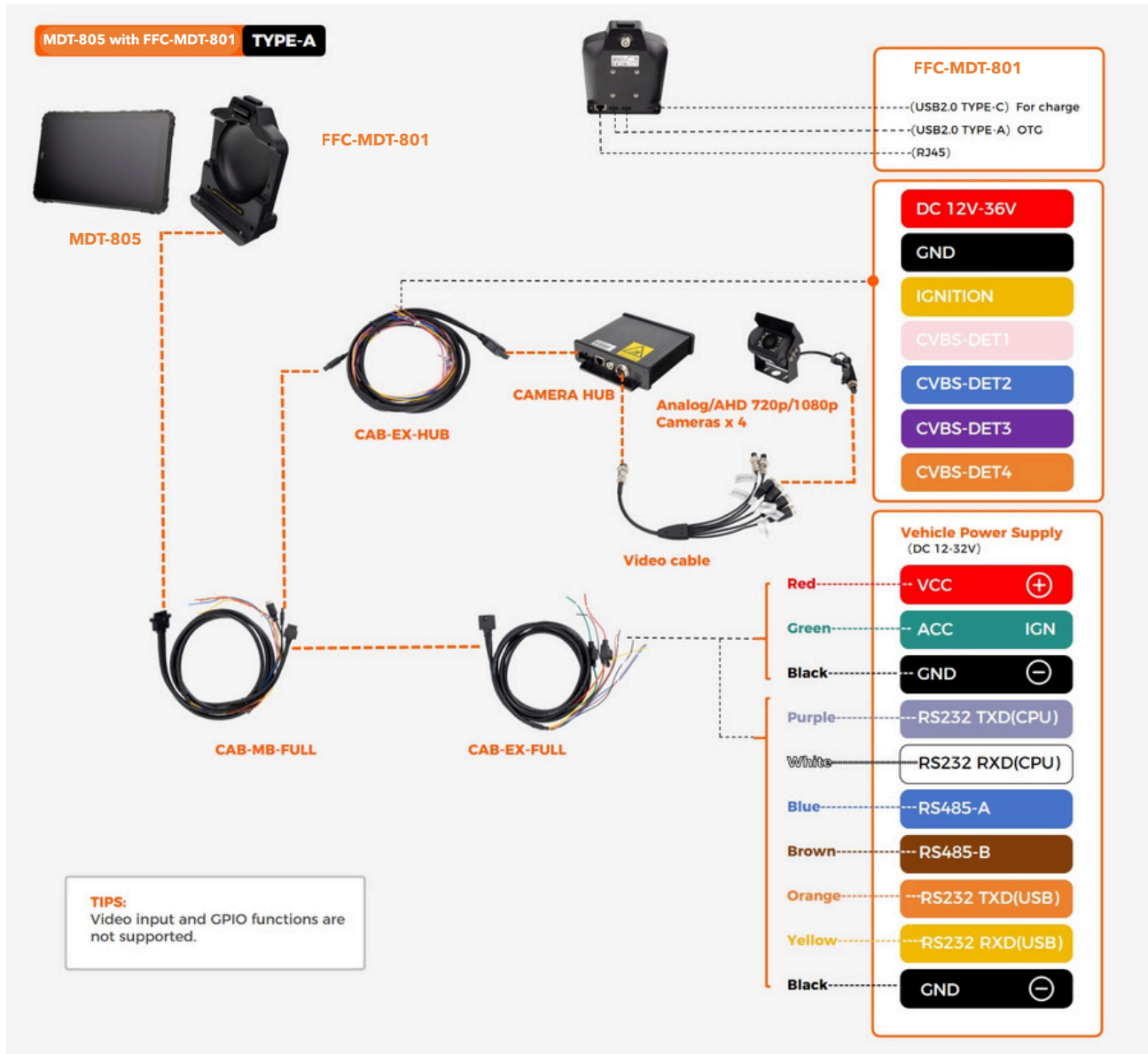

### 1.2.2.2 FFC-MDT-801 / BC-MDT-801 with BMW basic cables

It provides one RS232(CPU).

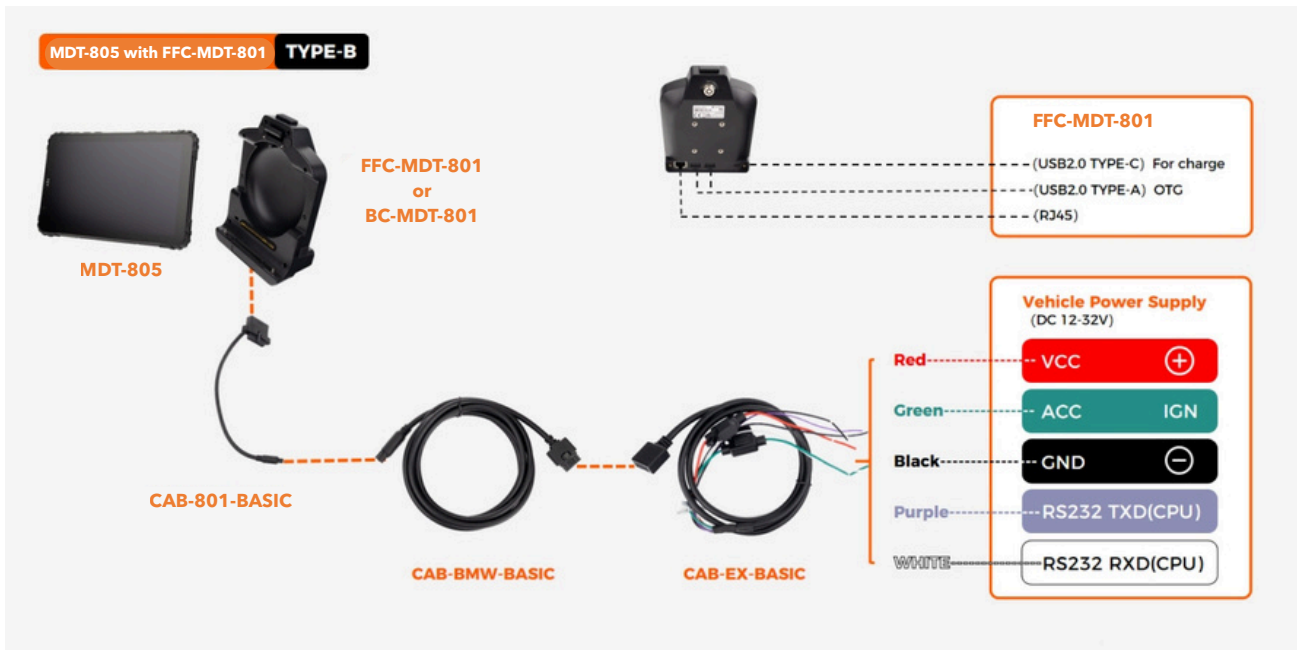

### 1.2.2.3 FFC-MDT-801 / BC-MDT-801 with USBA OTG cables

It provides one RS232 and one USBA OTG (USB 2.0).

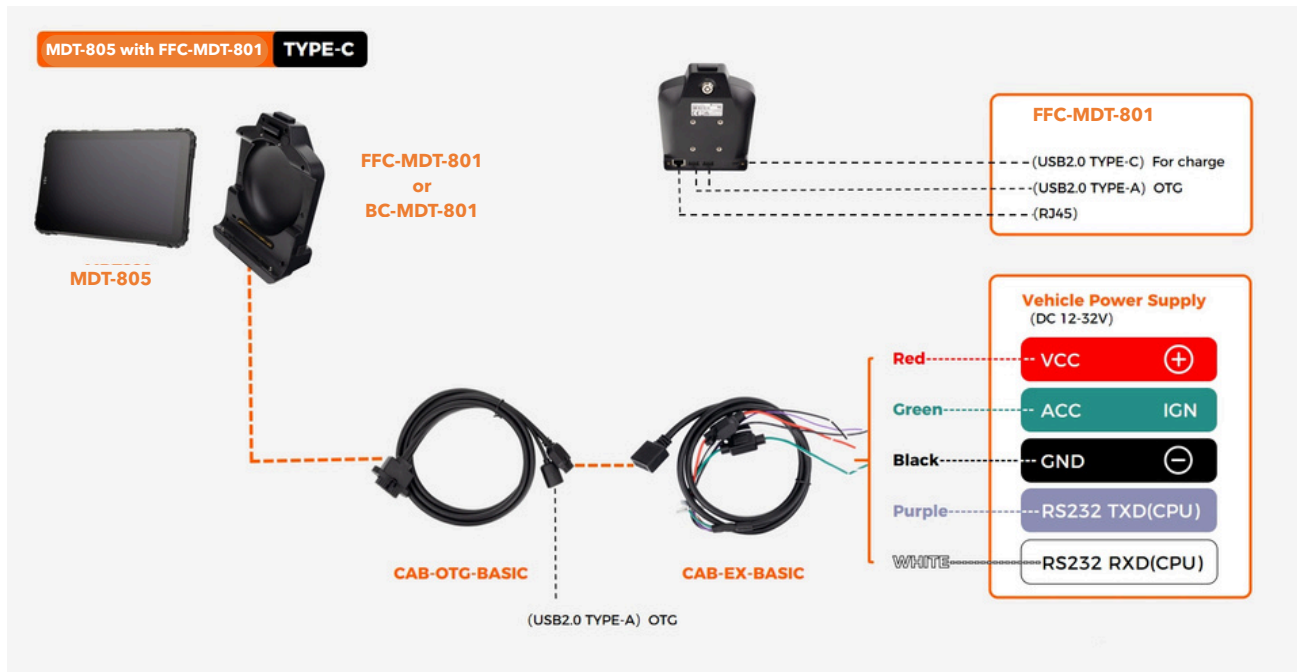

### 1.2.2.4 CRD-801-M12 with BMW basic cables

M12 connector for Ethernet.  
It provides one RS232(CPU).

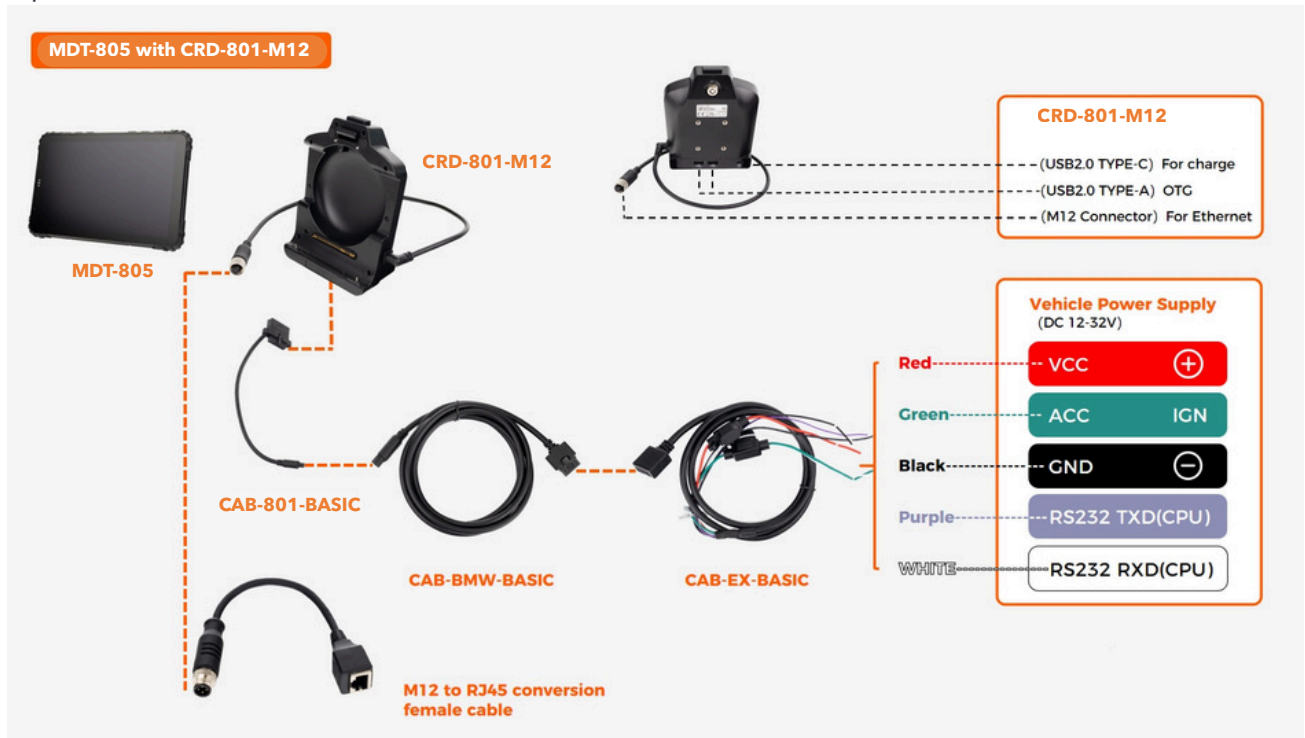

### 1.2.3 BKT801 Metal Bracket

#### 1.2.3.1 BKT-801 with waterproof cables

If you required waterproof, you can use the BKT-801 cradle.  
It provides one RS232.

Without ignition control switch in the bracket.



### 1.2.3.2 BKT-801-BMW with BMW basic cables

It provides one RS232.

Without ignition control in the bracket.



### 1.2.3.3 BKT-801-OTG with USBA OTG cable

It provides one RS232 and one USBA OTG (USB 2.0).

It does not support video input.

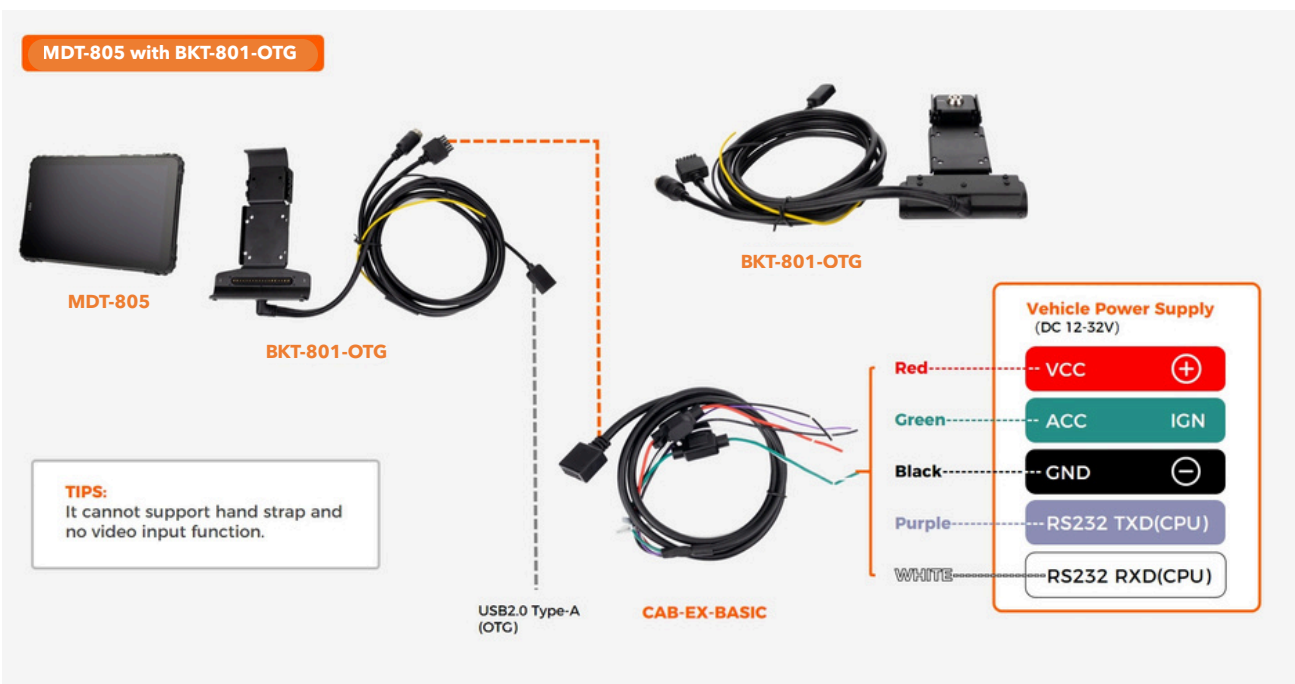

## 1.2.4 BKT-801-M12 Metal Bracket

### 1.2.4.1 BKT-801-M12 with M12 cable

M12 connector for Ethernet.  
It provides one RS232(CPU).

There is an ignition control switch inside the bracket.



### 1.2.4.2 BKT-801-BCR with Barcode Scanner

There is a 1D/2D Barcode Scanner on the cradle.  
M12 connector for Ethernet (optional).

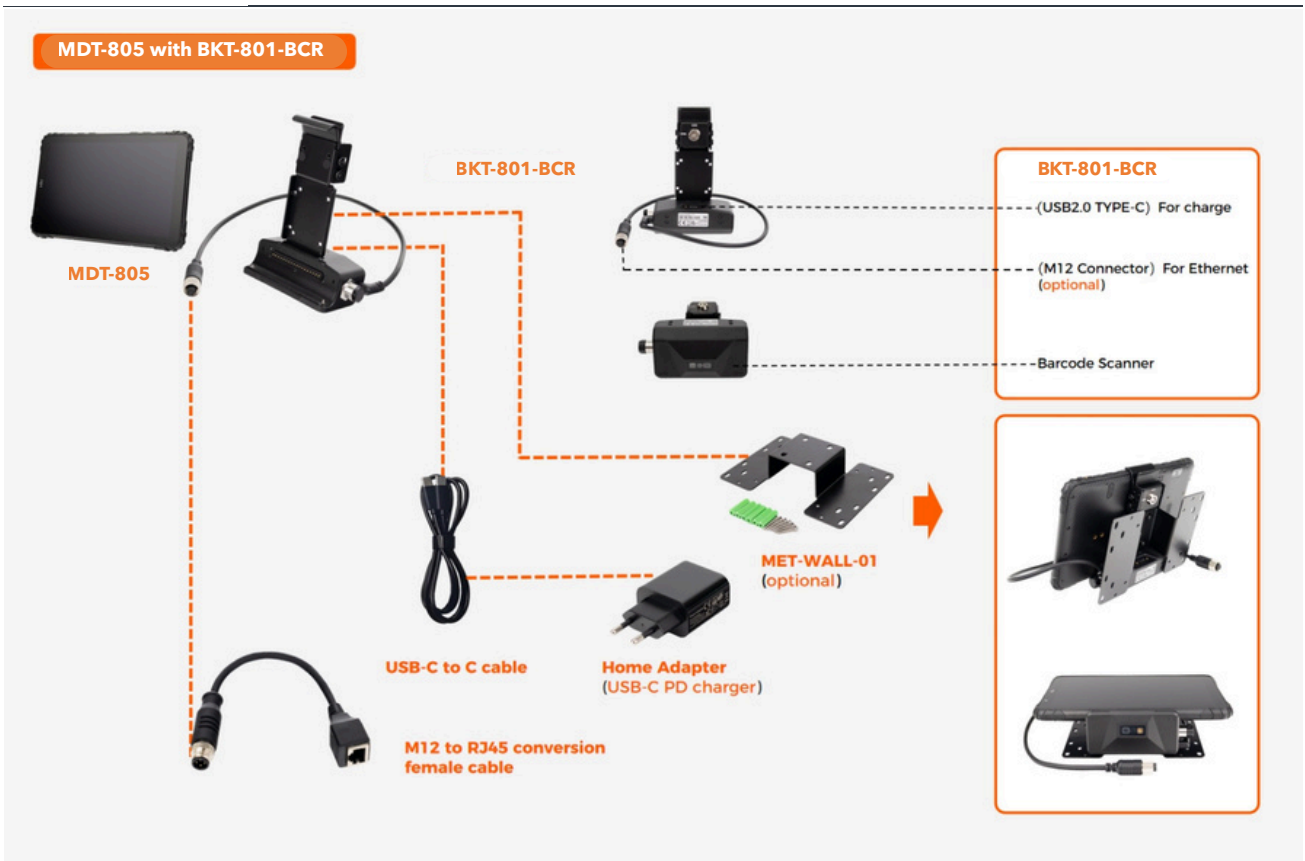

### 1.3 Cradle cable pin assignment overview

#### 1.3.1 Cradle cable with GPIO, RS232 and RS485 (CAB-FULL-BMW)

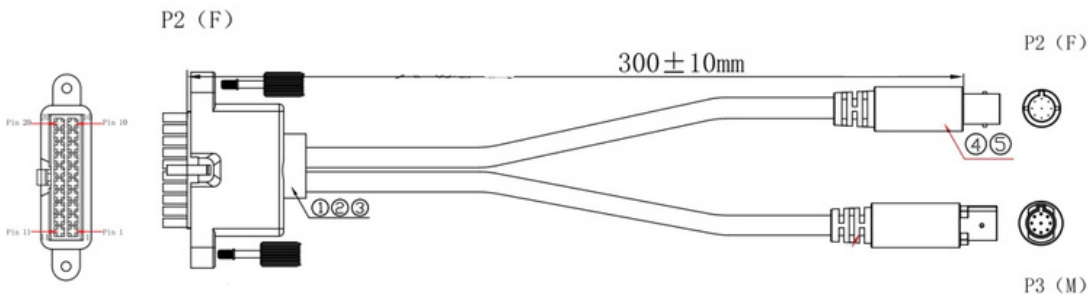

No	Item	Definition																				
P1	20 pin connector	Connect to the CRD805 full feature cradle																				
P2	9pin BMW Connector (Female)	Connect to the extension cable (CAB-BMW-BASIC + CAB-EX-BASIC)																				
		<table border="1"> <thead> <tr> <th>Pin1</th> <th>Pin2</th> <th>Pin3</th> <th>Pin4</th> <th>Pin5</th> </tr> </thead> <tbody> <tr> <td>VCC12-32V input</td> <td>ACC ignition</td> <td>Video Trigger</td> <td>Video input</td> <td>RXD (CPU)</td> </tr> <tr> <th>Pin6</th> <th>Pin7</th> <th>Pin8</th> <th>Pin9</th> <td></td> </tr> <tr> <td>TXD(CPU)</td> <td>Shield</td> <td>GND</td> <td>Camera DC 12V output</td> <td></td> </tr> </tbody> </table>	Pin1	Pin2	Pin3	Pin4	Pin5	VCC12-32V input	ACC ignition	Video Trigger	Video input	RXD (CPU)	Pin6	Pin7	Pin8	Pin9		TXD(CPU)	Shield	GND	Camera DC 12V output	
		Pin1	Pin2	Pin3	Pin4	Pin5																
		VCC12-32V input	ACC ignition	Video Trigger	Video input	RXD (CPU)																
Pin6	Pin7	Pin8	Pin9																			
TXD(CPU)	Shield	GND	Camera DC 12V output																			
P3	9pin BMW Connector (Male)	Connect to the GPIO/RS232/RS485 cable (CAB-EX-BMW)																				
		<table border="1"> <thead> <tr> <th>Pin1</th> <th>Pin2</th> <th>Pin3</th> <th>Pin4</th> <th>Pin5</th> </tr> </thead> <tbody> <tr> <td>GPIO-1(Input1)</td> <td>GPIO-3</td> <td>RS485-A</td> <td>RXD(USB)</td> <td>GND</td> </tr> </tbody> </table>	Pin1	Pin2	Pin3	Pin4	Pin5	GPIO-1(Input1)	GPIO-3	RS485-A	RXD(USB)	GND										
		Pin1	Pin2	Pin3	Pin4	Pin5																
GPIO-1(Input1)	GPIO-3	RS485-A	RXD(USB)	GND																		

			(Output)			
		Pin6	Pin7	Pin8	Pin9	
		GPIO-2 (Input 2)	GPIO-4 (ADC)	RS485-B	TXD(USB)	

### 1.3.2 GPIO, RS232 and RS485 extension cable

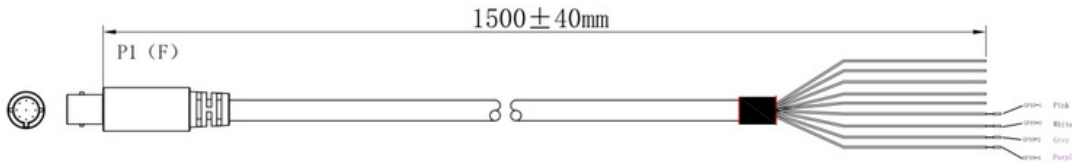

No	Item	Def inition				
P1	9pin BMW Connector (Female)	Connect to your GPIO/RS232/RS485 devices				
		Pink	White	Blue	Orange	Black
		GPIO-1(Input1)	GPIO-3(Output)	RS485-A	RXD(USB)	GND
		Grey	Purple	Brown	Yellow	
		GPIO-2(Input2)	GPIO-4(ADC)	RS485-B	TXD(USB)	

### 1.3.3 Basic features Cradle cable (CAB-BMW-BASIC)

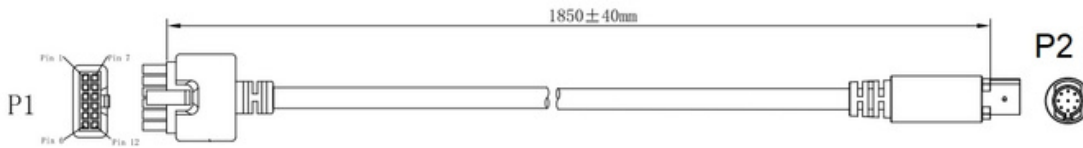

No	Item	Definition					
P1	Power Connector	Pin2	Pin3	Pin6	Pin9	Pin10	Pin11
		GND	RXD	ACC ignition	Shield	TXD	VCC 12-32V input
P2	9 pin BMW Connector M	Pin1	Pin2	Pin5	Pin6	Pin7	Pin8
		VCC 12-32V input	ACC ignition	RXD	TXD	Shield	GND

### 1.3.4 Full features Cradle cable (CAB-MB-FULL)

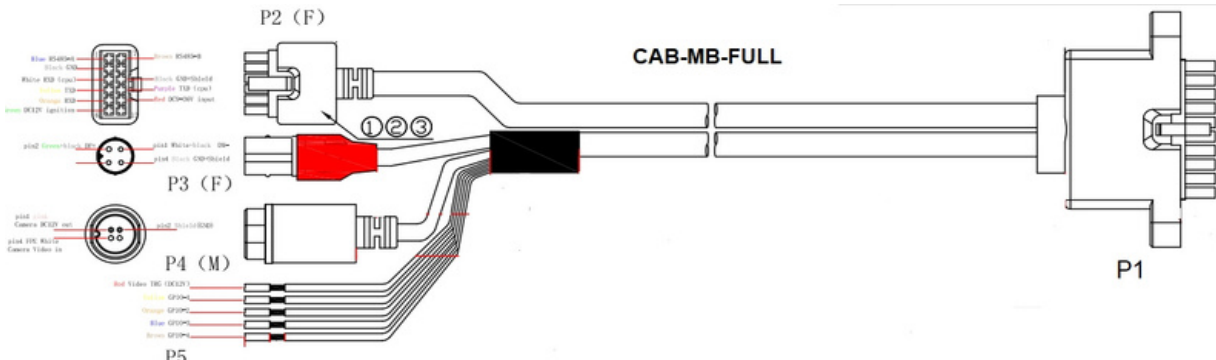

No	Item	Definition										
P1	20pin Micro-Fit connector	Connect to the full feature cradle										
P2	12pin Micro-Fit connector	Connect to the extension cable (CAB-EX-FULL)										
		<table border="1"> <thead> <tr> <th>Pin1</th> <th>Pin2</th> <th>Pin3</th> <th>Pin4</th> <th>Pin5</th> </tr> </thead> <tbody> <tr> <td>RS485-A</td> <td>GND</td> <td>RS232RXD(CPU)</td> <td>RS232TXD(USB)</td> <td>RS232 RXD (USB)</td> </tr> </tbody> </table>	Pin1	Pin2	Pin3	Pin4	Pin5	RS485-A	GND	RS232RXD(CPU)	RS232TXD(USB)	RS232 RXD (USB)
		Pin1	Pin2	Pin3	Pin4	Pin5						
		RS485-A	GND	RS232RXD(CPU)	RS232TXD(USB)	RS232 RXD (USB)						
<table border="1"> <thead> <tr> <th>Pin6</th> <th>Pin7</th> <th>Pin9</th> <th>Pin10</th> <th>Pin11</th> </tr> </thead> <tbody> <tr> <td>ACC ignition</td> <td>RS485-B</td> <td>GND</td> <td>RS232TXD(CPU)</td> <td>VCC12-32Vinput</td> </tr> </tbody> </table>	Pin6	Pin7	Pin9	Pin10	Pin11	ACC ignition	RS485-B	GND	RS232TXD(CPU)	VCC12-32Vinput		
Pin6	Pin7	Pin9	Pin10	Pin11								
ACC ignition	RS485-B	GND	RS232TXD(CPU)	VCC12-32Vinput								
P3	4pin BMW Connector F	Connect to the 4pin BMW connector on the camera hub cable (CAB-EX-HUB)										
		<table border="1"> <thead> <tr> <th>Pin1</th> <th>Pin2</th> <th>Pin4</th> </tr> </thead> <tbody> <tr> <td>DM-</td> <td>DP+</td> <td>GND</td> </tr> </tbody> </table>	Pin1	Pin2	Pin4	DM-	DP+	GND				
		Pin1	Pin2	Pin4								
DM-	DP+	GND										
<input type="checkbox"/> Note: Video input and GPIO are not supported.												

### 1.3.5 Cradle extension cable (CAB-EX-FULL)

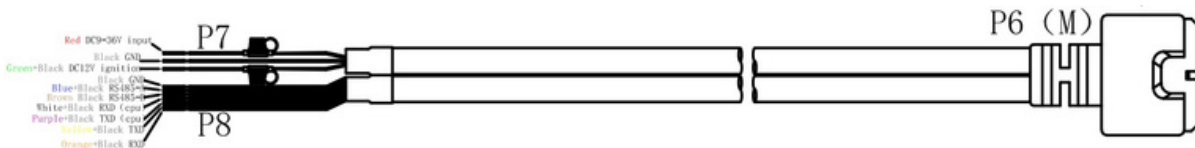

No	Item	Definition														
P6	12pin Micro-Fit connector	Connect to the P2 connector on the cradle cable (CAB-MB-FULL)														
P7	Power Supply wires	Connect to the vehicle battery.														
		<table border="1"> <thead> <tr> <th>Red</th> <th>Green</th> <th>Black</th> </tr> </thead> <tbody> <tr> <td>VCC12-32Vinput</td> <td>ACC ignition</td> <td>GND</td> </tr> </tbody> </table>	Red	Green	Black	VCC12-32Vinput	ACC ignition	GND								
Red	Green	Black														
VCC12-32Vinput	ACC ignition	GND														
P8	Serial port wires	1 x RS485, 2 x RS232 (White/Purple RS232 same as old model MDT-760/MDT-860 serial port)														
		<table border="1"> <thead> <tr> <th>Blue</th> <th>Brown</th> <th>Yellow</th> <th>Orange</th> <th>White</th> <th>Purple</th> <th>Black</th> </tr> </thead> <tbody> <tr> <td>RS485-A</td> <td>RS485-B</td> <td>TXD(USB)</td> <td>RXD(USB)</td> <td>RXD(CPU)</td> <td>TXD(CPU)</td> <td>GND</td> </tr> </tbody> </table>	Blue	Brown	Yellow	Orange	White	Purple	Black	RS485-A	RS485-B	TXD(USB)	RXD(USB)	RXD(CPU)	TXD(CPU)	GND
		Blue	Brown	Yellow	Orange	White	Purple	Black								
RS485-A	RS485-B	TXD(USB)	RXD(USB)	RXD(CPU)	TXD(CPU)	GND										

### 1.3.6 Camera hub cable (CAB-EX-HUB)

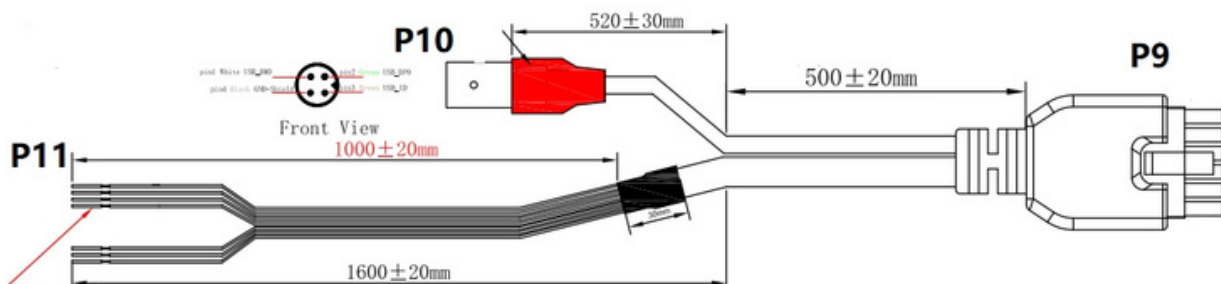

No	Item	Definition												
P9	12pin Micro-Fit connector	Connect to the Camera Hub HH421.												
P10	4pin BMW Connector M	Connect to the 4pin BMW connector on the full feature cradle cable (CAB-MB-FULL).												
		<table border="1"> <thead> <tr> <th>Pin1</th> <th>Pin2</th> <th>Pin3</th> <th>Pin4</th> </tr> </thead> <tbody> <tr> <td>DM-</td> <td>DP+</td> <td>ID</td> <td>GND</td> </tr> </tbody> </table>	Pin1	Pin2	Pin3	Pin4	DM-	DP+	ID	GND				
Pin1	Pin2	Pin3	Pin4											
DM-	DP+	ID	GND											
P11	Trigger wires	4 channels trigger for camera.												
		<table border="1"> <thead> <tr> <th>Pink</th> <th>Blue</th> <th>Purple</th> <th>Orange</th> <th>Black</th> <th>Yellow</th> <th>Red</th> </tr> </thead> <tbody> <tr> <td>CVBS_DET1</td> <td>CVBS_DET2</td> <td>CVBS_DET3</td> <td>CVBS_DET4</td> <td>GND</td> <td>ACC ignition</td> <td>VCC 12-32V input</td> </tr> </tbody> </table>	Pink	Blue	Purple	Orange	Black	Yellow	Red	CVBS_DET1	CVBS_DET2	CVBS_DET3	CVBS_DET4	GND
Pink	Blue	Purple	Orange	Black	Yellow	Red								
CVBS_DET1	CVBS_DET2	CVBS_DET3	CVBS_DET4	GND	ACC ignition	VCC 12-32V input								

### 1.3.7 Basic features Cradle cable (CAB-OTG-BASIC)

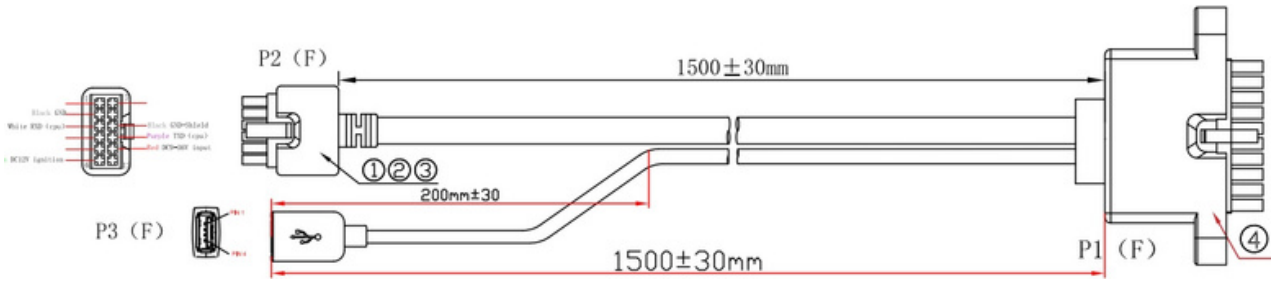

No	Item	Definition																
P1	Cradle Connector	<table border="1"> <thead> <tr> <th>Pin3</th> <th>Pin8</th> <th>Pin9</th> <th>Pin10</th> <th>Pin13</th> <th>Pin18</th> <th>Pin19</th> <th>Pin20</th> </tr> </thead> <tbody> <tr> <td>ACC ignition</td> <td>RXD</td> <td>GND</td> <td>D+</td> <td>VCC 12-32V input</td> <td>TXD</td> <td>VBUS5V</td> <td>D-</td> </tr> </tbody> </table>	Pin3	Pin8	Pin9	Pin10	Pin13	Pin18	Pin19	Pin20	ACC ignition	RXD	GND	D+	VCC 12-32V input	TXD	VBUS5V	D-
		Pin3	Pin8	Pin9	Pin10	Pin13	Pin18	Pin19	Pin20									
ACC ignition	RXD	GND	D+	VCC 12-32V input	TXD	VBUS5V	D-											
<table border="1"> <thead> <tr> <th>Pin2</th> <th>Pin3</th> <th>Pin6</th> <th>Pin9</th> <th>Pin10</th> <th>Pin11</th> </tr> </thead> <tbody> <tr> <td>GND</td> <td>RXD</td> <td>ACC ignition</td> <td>GND</td> <td>TXD</td> <td>VCC 12-32V input</td> </tr> </tbody> </table>	Pin2	Pin3	Pin6	Pin9	Pin10	Pin11	GND	RXD	ACC ignition	GND	TXD	VCC 12-32V input						
Pin2	Pin3	Pin6	Pin9	Pin10	Pin11													
GND	RXD	ACC ignition	GND	TXD	VCC 12-32V input													
P3	USB	USB Type-A (cannot be used simultaneously with USB Type-C on the device)																

### 1.3.8 Basic features Cradle extension cable (CAB-EX-BASIC)

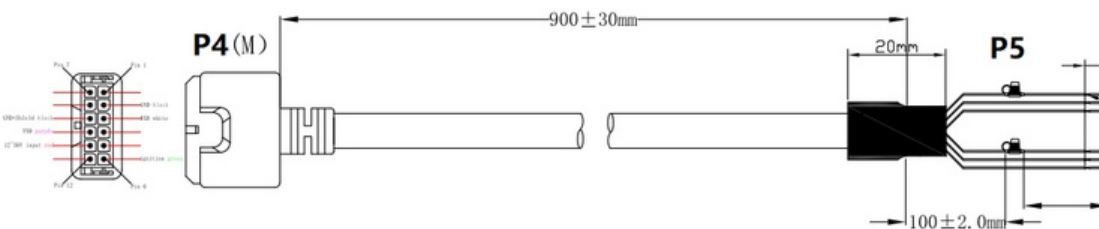

No	Item	Definition										
P4	12pin Micro-Fit connector	Connect to the basic features cradle cable P2 connector.										
P5	Power Supply and Serial port wires	It can be connected to the vehicle battery.										
		<table border="1"> <tr> <td>Red</td> <td>Green</td> <td>Black</td> <td>White</td> <td>Purple</td> </tr> <tr> <td>VCC12-32V input</td> <td>ACC ignition</td> <td>GND</td> <td>RXD</td> <td>TXD</td> </tr> </table>	Red	Green	Black	White	Purple	VCC12-32V input	ACC ignition	GND	RXD	TXD
		Red	Green	Black	White	Purple						
VCC12-32V input	ACC ignition	GND	RXD	TXD								

Note: These two basic feature cables can also be used for a full feature cradle.

### 1.3.9 L-Shape cradle cable (CAB-801-BASIC)

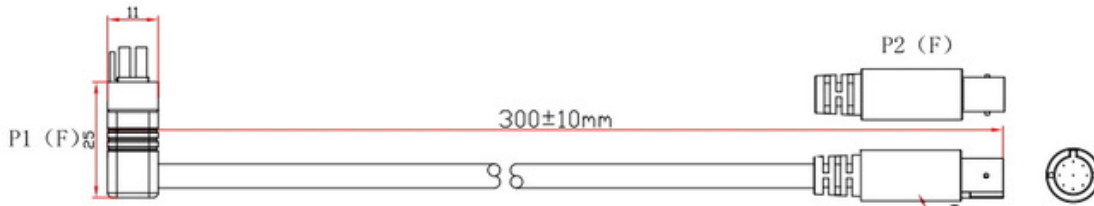

No	Item	Definition																								
P1	Cradle Connector	<table border="1"> <tr> <td>Pin1</td> <td>Pin2</td> <td>Pin3</td> <td>Pin8</td> <td>Pin9</td> <td>Pin11</td> </tr> <tr> <td>Shield</td> <td>VideoTrigger</td> <td>ACC ignition</td> <td>RXD</td> <td>GND</td> <td>Video input</td> </tr> <tr> <td>Pin12</td> <td>Pin13</td> <td>Pin18</td> <td colspan="3"></td> </tr> <tr> <td>Camera DC12V output</td> <td>VCC 12-32V input</td> <td>TXD</td> <td colspan="3"></td> </tr> </table>	Pin1	Pin2	Pin3	Pin8	Pin9	Pin11	Shield	VideoTrigger	ACC ignition	RXD	GND	Video input	Pin12	Pin13	Pin18				Camera DC12V output	VCC 12-32V input	TXD			
		Pin1	Pin2	Pin3	Pin8	Pin9	Pin11																			
		Shield	VideoTrigger	ACC ignition	RXD	GND	Video input																			
		Pin12	Pin13	Pin18																						
Camera DC12V output	VCC 12-32V input	TXD																								
P2	9 pin BMW Connector F	<table border="1"> <tr> <td>Pin1</td> <td>Pin2</td> <td>Pin3</td> <td>Pin4</td> </tr> <tr> <td>VCC 12-32V input</td> <td>ACC ignition</td> <td>VideoTrigger</td> <td>Video input</td> </tr> <tr> <td>Pin5</td> <td>Pin6</td> <td>Pin7</td> <td>Pin8</td> <td>Pin9</td> </tr> <tr> <td>RXD</td> <td>TXD</td> <td>Shield</td> <td>GND</td> <td>Camera DC12V output</td> </tr> </table>	Pin1	Pin2	Pin3	Pin4	VCC 12-32V input	ACC ignition	VideoTrigger	Video input	Pin5	Pin6	Pin7	Pin8	Pin9	RXD	TXD	Shield	GND	Camera DC12V output						
		Pin1	Pin2	Pin3	Pin4																					
		VCC 12-32V input	ACC ignition	VideoTrigger	Video input																					
		Pin5	Pin6	Pin7	Pin8	Pin9																				
RXD	TXD	Shield	GND	Camera DC12V output																						

### 1.3.10 Basic features Cradle cable (CAB-BMW-BASIC)

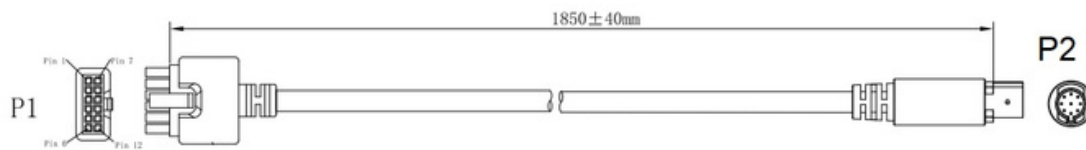

No	Item	Definition												
P1	Power Connector	<table border="1"> <tr> <td>Pin2</td> <td>Pin3</td> <td>Pin6</td> <td>Pin9</td> <td>Pin10</td> <td>Pin11</td> </tr> <tr> <td>GND</td> <td>RXD</td> <td>ACC ignition</td> <td>Shield</td> <td>TXD</td> <td>VCC 12-32V input</td> </tr> </table>	Pin2	Pin3	Pin6	Pin9	Pin10	Pin11	GND	RXD	ACC ignition	Shield	TXD	VCC 12-32V input
		Pin2	Pin3	Pin6	Pin9	Pin10	Pin11							
GND	RXD	ACC ignition	Shield	TXD	VCC 12-32V input									
P2	9 pin BMW Connector M	<table border="1"> <tr> <td>Pin1</td> <td>Pin2</td> <td>Pin5</td> <td>Pin6</td> <td>Pin7</td> <td>Pin8</td> </tr> <tr> <td>VCC 12-32V input</td> <td>ACC ignition</td> <td>RXD</td> <td>TXD</td> <td>Shield</td> <td>GND</td> </tr> </table>	Pin1	Pin2	Pin5	Pin6	Pin7	Pin8	VCC 12-32V input	ACC ignition	RXD	TXD	Shield	GND
Pin1	Pin2	Pin5	Pin6	Pin7	Pin8									
VCC 12-32V input	ACC ignition	RXD	TXD	Shield	GND									

### 1.3.11 Molex to Molex 2meter and 5meter extension cables

#### CAB-EX-2M

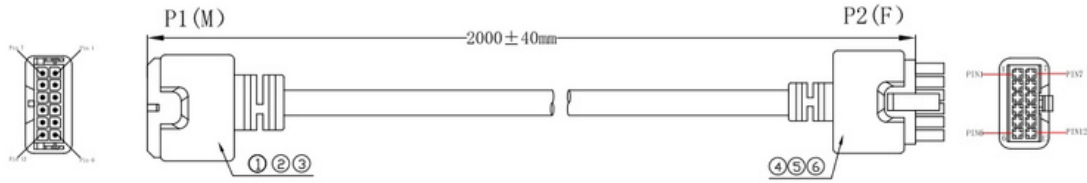

CAB-EX-5M

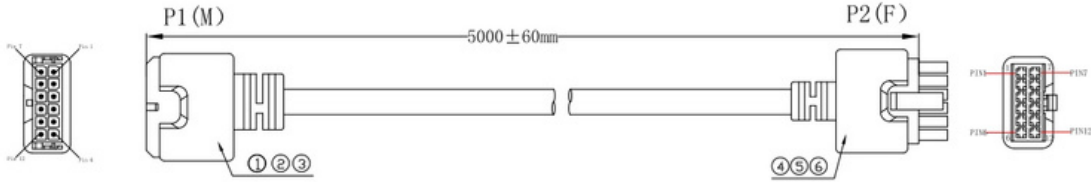

No	Item	Definition							
P1	12pin Molex Male	Pin2	Pin3	Pin4	Pin5	Pin6	Pin9	Pin10	Pin11
		GND	RXD (CPU)	TXD (USB)	RXD (USB)	ACC IGN	Shield	TXD (CPU)	VCC DC12-32V input
P2	12pin Molex Female	Pin2	Pin3	Pin4	Pin5	Pin6	Pin9	Pin10	Pin11
		GND	RXD (CPU)	TXD (USB)	RXD (USB)	ACC IGN	Shield	TXD (CPU)	VCC DC12-32V input

1.3.12 Basic feature cable with waterproof connector (BKT-801-BAS-01)

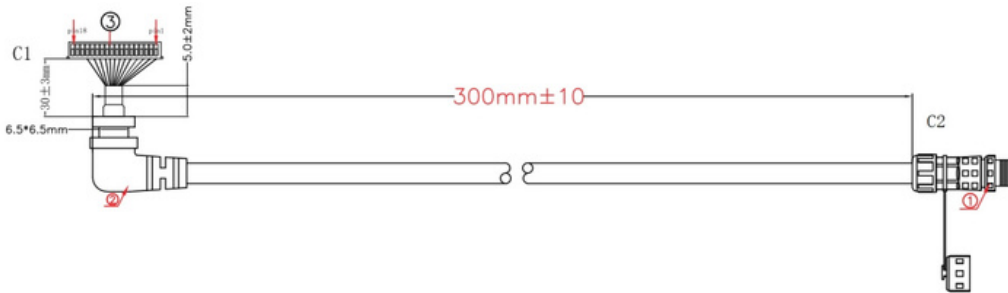

No	Item	Definition					
C1	Housing 18pin	Pin6	Pin7	Pin10	Pin12 VCC	Pin17	Pin18
		TXD	RXD	ACC ignition	input 12-32V	GND	GND
C2	6pin Waterproof Connector M	Pin1	Pin2	Pin3	Pin4	Pin5	Pin6
		GND	TXD	GND	RXD	ACC ignition	VCC

1.3.13 Basic feature cable with waterproof connector for MDT-805 (BKT801-BAS-02)

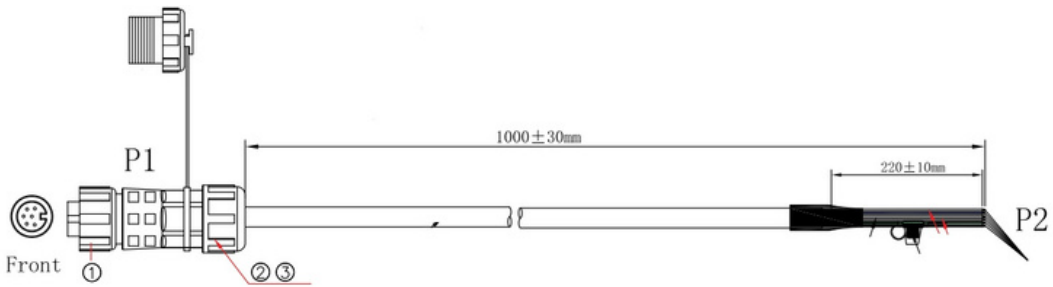

No	Item	Definition					
		Pin1	Pin2	Pin3	Pin4	Pin5	Pin6
P1	6pin Waterproof Connector F	GND	TXD	GND	RXD	ACC ignition	VCC
		Black	Purple	Black	White	Green	Red
P2	Wires	GND	TXD	GND	RXD	ACC ignition	VCC

## 1.3 Accessories

### 1.3.1 Cradles



**CRD805**  
Full feature cradle (with max 4 video input)



**FFC-MDT-801**  
Full feature cradle (Ethernet, OTGx2)



**CRD-801-M12**  
Full feature cradle (Ethernet with M12 cable, OTG 2x)



**BC-MDT-801**  
Basic feature cradle



**BKT-801-BMW**  
with BMW connector



**BKT-801**  
with waterproof connector

These two metal brackets only vehicle charging 12-24V input, IGN, GND and 1 RS232.



**BKT-801-M12**  
with M12 cable (for ethernet) and another M12 connector (for Vcc, IGN, GND and GRS232)



**BKT-801-BCR**  
metal bracket with 1D/2D barcode at the bottom

## 1.3.2 Expansion Modules

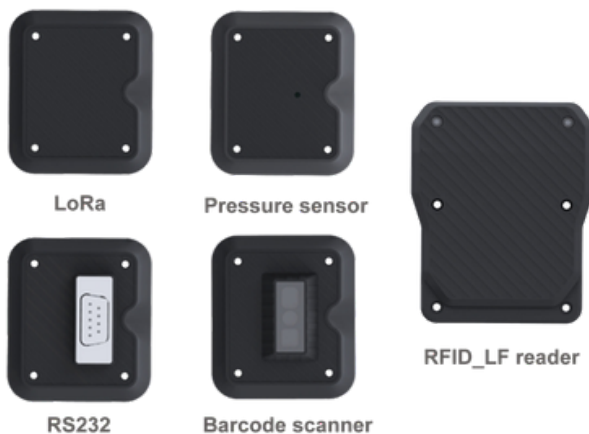

- Barcode Scanner: MDT-LDT-X01-BCR (SE4107 barcode module)
- LoRa Module: MDT-LDT-X01-LOR (For temperature sensor)
- Pressure sensor: MOD-PRE-01 (Air pressure sensor)
- RS232 module: MOD-RS232-01
- RFID LF Reader: MOD-LF-01 (support 125kHz/134.2kHz)

### 1.3.3 Chargers



**ADA-HOME-01**  
Quick charge home adapter



**ADA-CAR-01**  
Car charger



**MDT-LDT-X01-MCC**



**ADA-HOME-02**  
Quick charge home adapter with optional plug

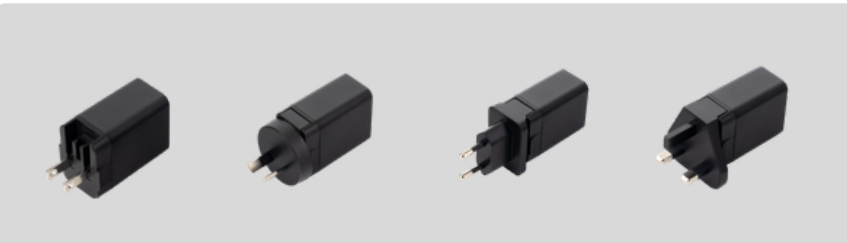

with US plug    with AU plug    with EU plug    with UK plug

### 1.3.4 Other Accessories



**PB-SCM**  
(2 x round plate, 6cm arm)



**PB-SCM2**  
(2 x round plate, 9cm arm)

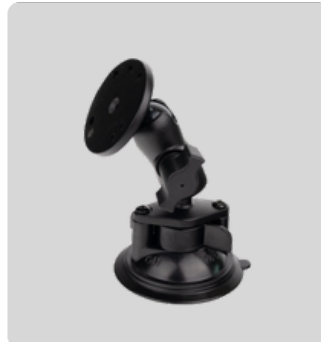

**PB-SUM**  
(1 x round plate, 6cm arm,  
suction cup)



**MET-WALL-02**  
wall mount plate



**MDT-801-EA**  
external GPS antenna  
(with L-shape cable)



**MDT-801-EA2**  
conversion cable  
(MMCX to SMA female)



**MDT-801-CAP**  
Sunshield Cap to attach  
to the tablet and block  
sunlight



**MDT-801-CASE**  
Ultra protection case (not  
compatible with sunshield  
and module)



**STR-HAND-01**  
Hand strap



**MET-BOT-01**  
Bottom metal plate



**MDT-801-SPR-GAG**  
7H glass screen  
protector (Anti-Glare)

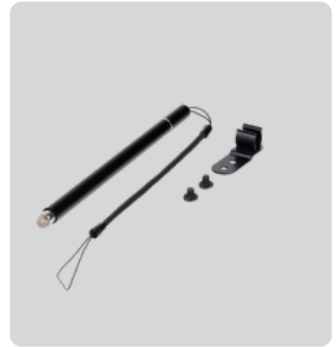

**PB-101-SP**  
Stylus pen, tether and  
holder



**ACC-WALKIE-01**  
Walkie talkie



**SCREW-01**  
Screw driver for  
SIM card cover



**BAG-80X-01**  
Carry bag



**BAG-80X-02**

## Chapter 2: Getting Started

### 2.1 Power On/Off and Sleep/Wake

This Chapter is describing how to power on/off the device, put the device into sleep mode (screen saver) and force restart. Proper operation of power on/off the device will be beneficial to ensure the stability of the system. The device status indicated by the color of the indicator is as described in the following table for the standard.

Table 2.1.1 Indicator color and device status table

LEDs Behavior	Device Status
Red light on	Charging
Green light on	Fully charged
Light off	High temperature causes stop charging.
Red light on	High temperature causes shutdown.
Red or Green light blinking	Notification (Sleep when charging)

#### 1. Power on the Device

- a. Power on by pressing the power button: Long press the power button for more than 2 seconds until the boot screen displayed. It needs around 20 seconds to start the system.
- b. Power consumption during operation: 15W (typical).

#### 2. Power off the Device

- a. Power off by pressing the button: In the status of working on the device desktop, long press the power button for more than 2 seconds until the shutdown prompt pop-up then click the "Power off" option.
- b. The consumption during power off (with docking station): around 250mW.

#### 3. Sleep and Wake the Device

- a. Auto sleep, the sleep time can be set up in the settings.
- b. Short press button to sleep.
- c. Short press to wake.
- d. Wake up by ignition ON.

#### 4. Restart the device

Restart by pressing the button: In the status of working on the device desktop, long press the power button for more than 2 seconds until the prompt pop-up then click the "Restart" option.

## 2.2 Installing Micro SD and SIM Card

To install the Micro SD card and/or Nano SIM card.

- Find the Nano SIM card slot and the Micro SD card slot. The following graphics illustrates the correct cards orientation.
- For easier removing the Nano SIM card and Micro SD card from the inside card slot, please assist with the Nano SIM card and Micro SD card tape as shown in the figure.
- SIM card and Micro SD card cover can be locked by screws in preventing from loss or steal.

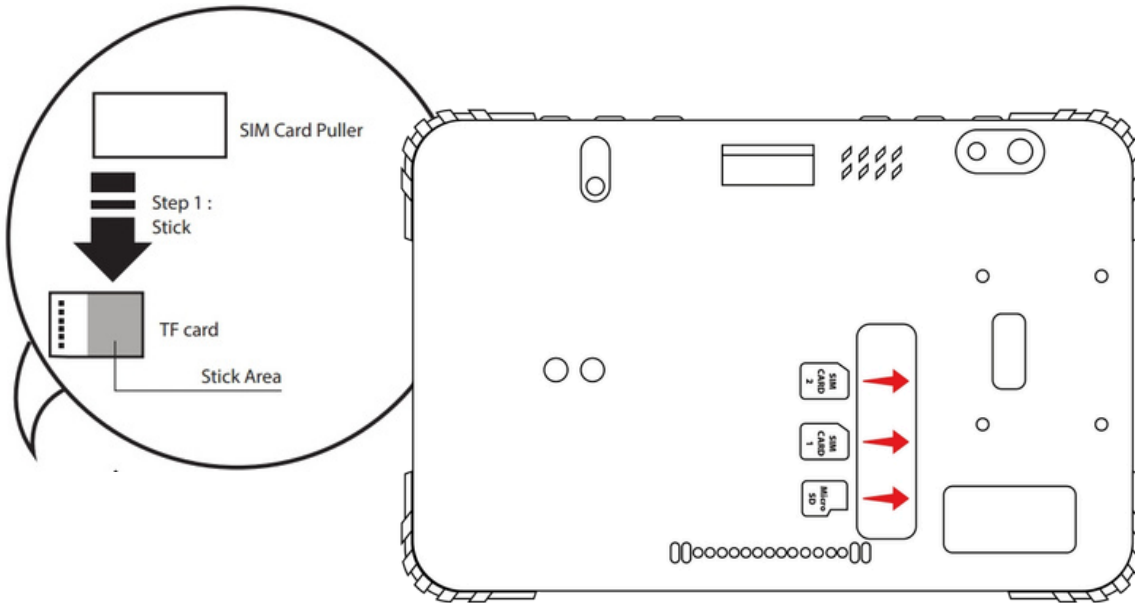

## 2.3 Charging the Battery

The battery is built-in and cannot be removed by the user.

The battery is partially drained during the transportation. Be sure to charge the battery to full when you are charging it for the first time.

Tips:

In order to ensure the life and performance of the battery, if your tablet has been stored in the warehouse for more than three months, it is recommended to charge the battery every three months.

## 2.4 Charging with the vehicle power supply

To charge the battery with the vehicle power supply:

a) If the device with an optional cradle, then put the tablet on the cradle, connect the cradle to the vehicle power supply.

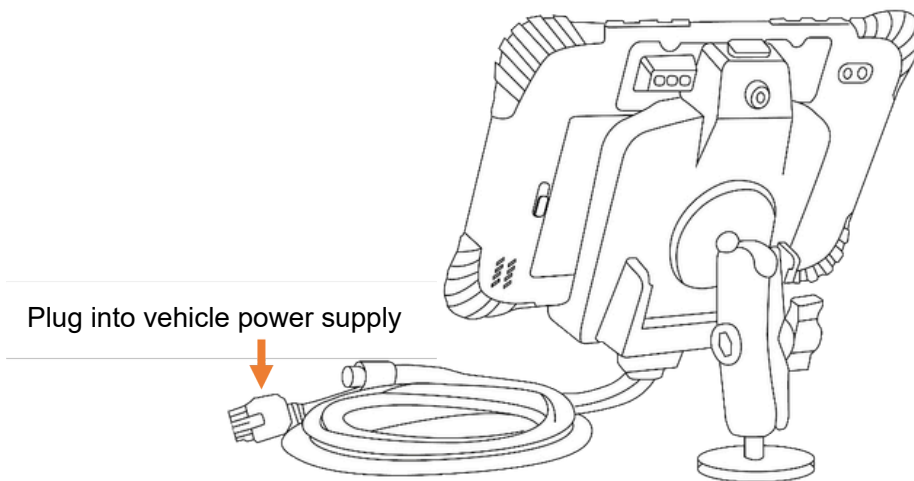

b) The MDT-805 could be charged by a PD fast-charging Adapter or car charger (5V/3A,9V/2A,12/2A) by Type C to C USB cable.

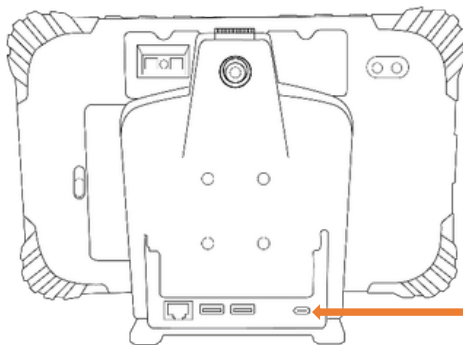

Connect to AC adapter or Car charger  
(the cradle may not able to charge if  
only use standard 5V/2A adapter)

Warning:

Please ensure that the input voltage of the cradle is within the range of 12V~32V. If the input voltage of the cradle is outside this range, the MDT-805 may be unable to charge or damaged. It may cause the warranty invalid.

## Chapter 3: Hand strap and shoulder strap mode

### 3.1 Hand strap

#### 1) How to install

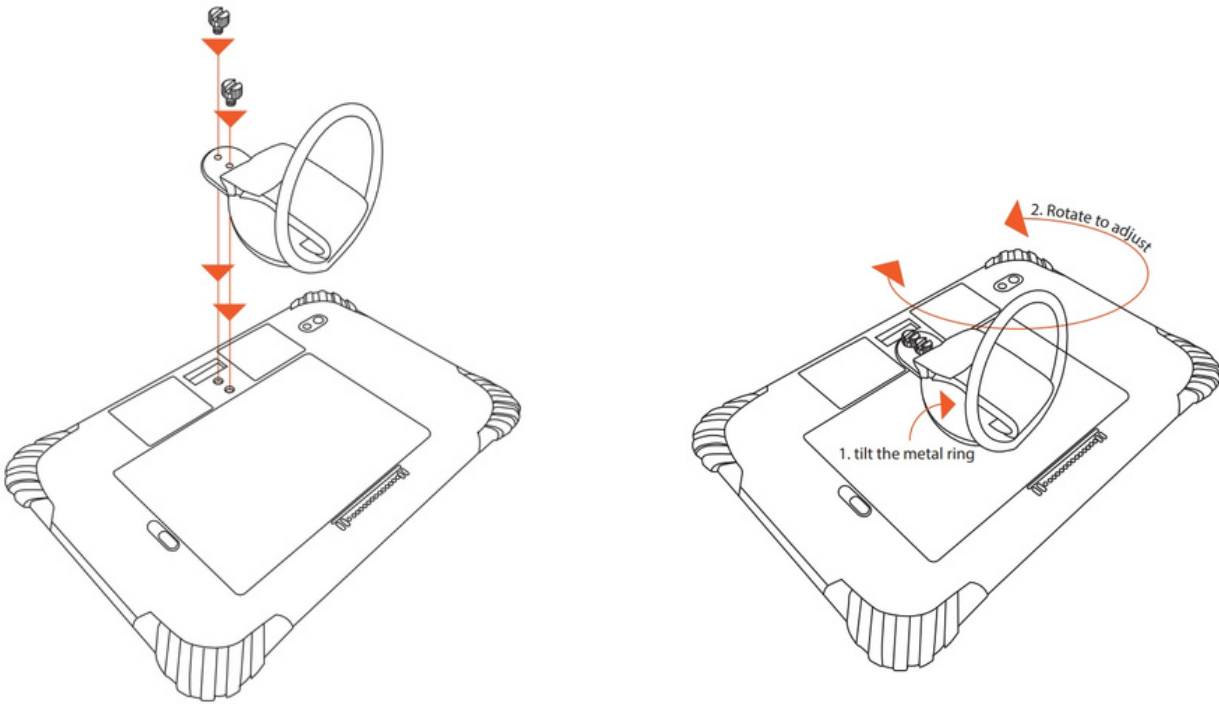

#### 2) How to use

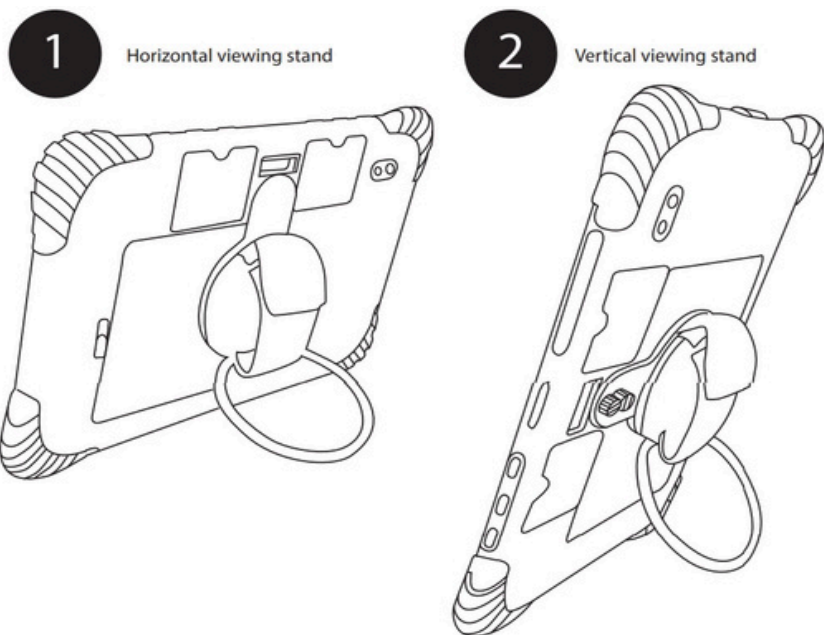

Easy to carry

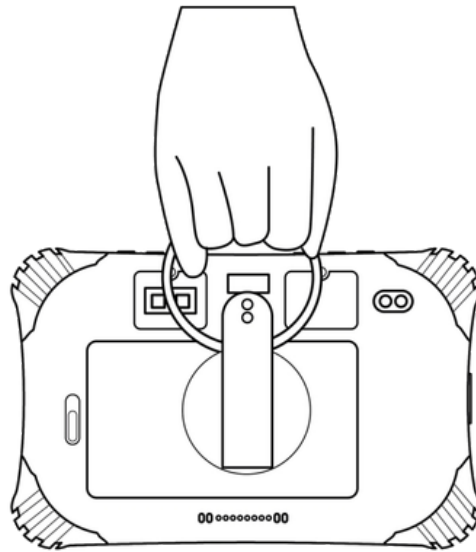

**3** Adjustable viewing hand strap

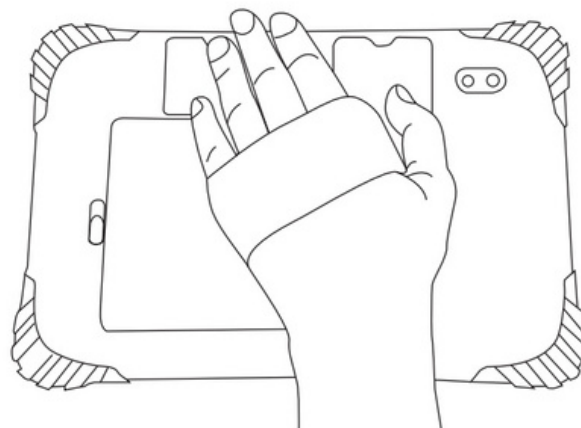
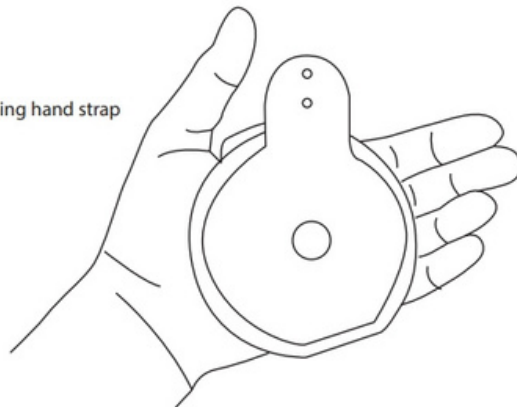

## Chapter 4: Cradle Using Instruction

### 4.1 To be vehicle cradle

#### 1) Mounting the Screw Mount and Cradle Assemble with cradle (Be a vehicle cradle)

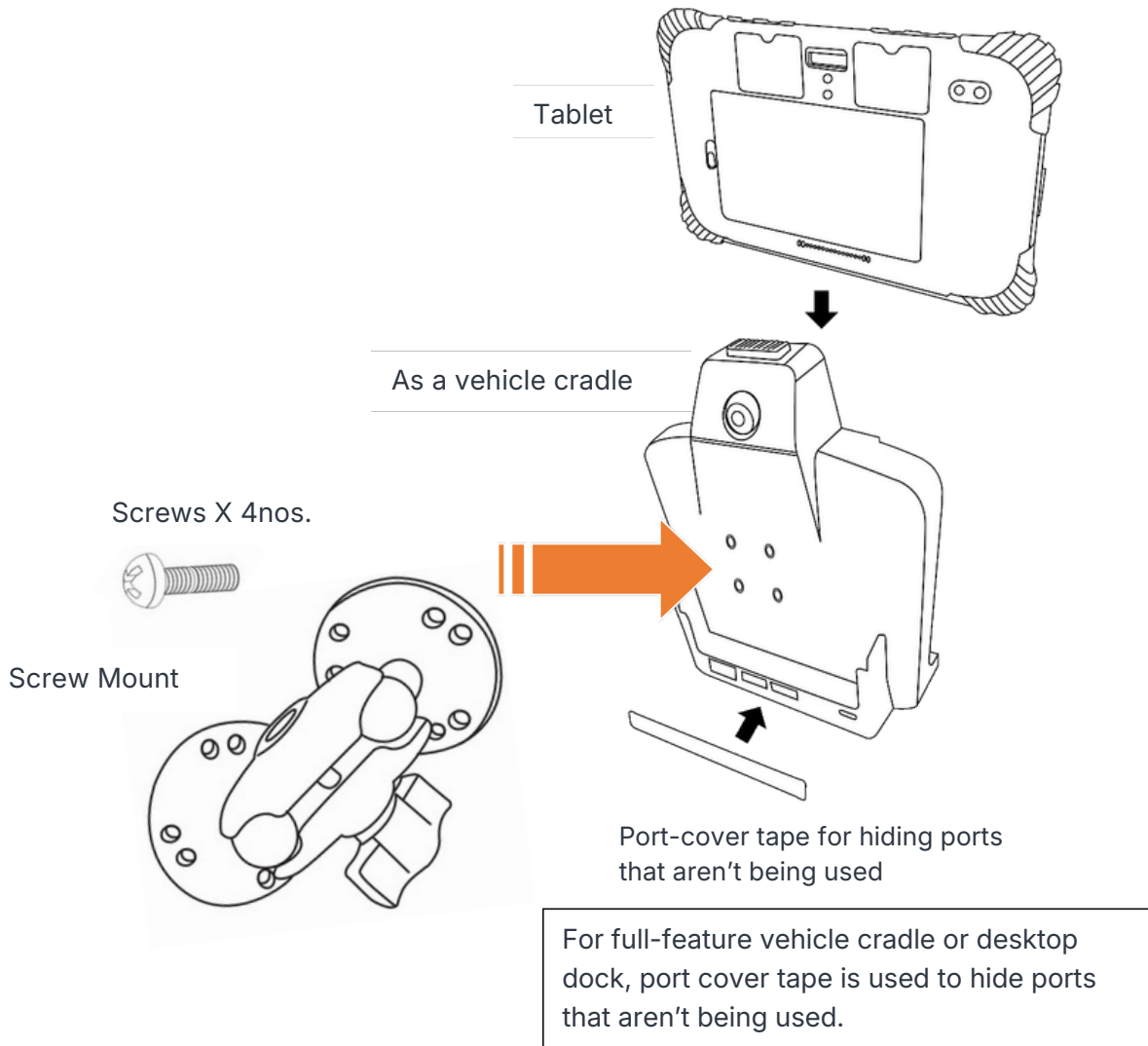

## 1. Locking Device & Unlocking device

Insert the key to lock or unlock the device

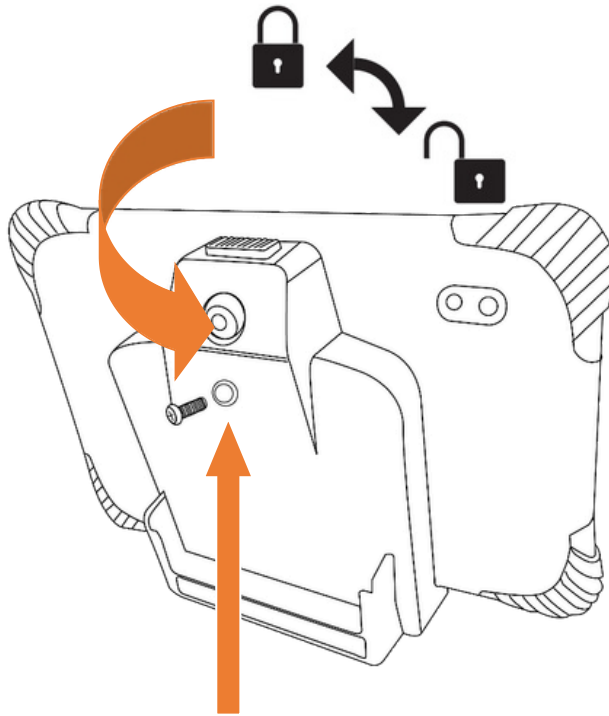

Screw-in the screws to make the lock more secure

## 4.2 To be a desktop dock station

### 1. Install the Metal Stand

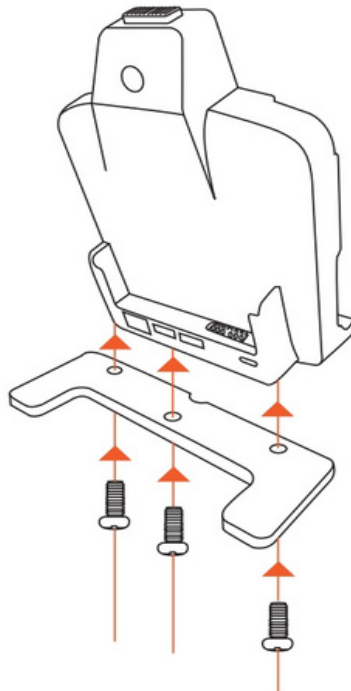

## 2. Assemble with cradle (Be a desktop dock station)

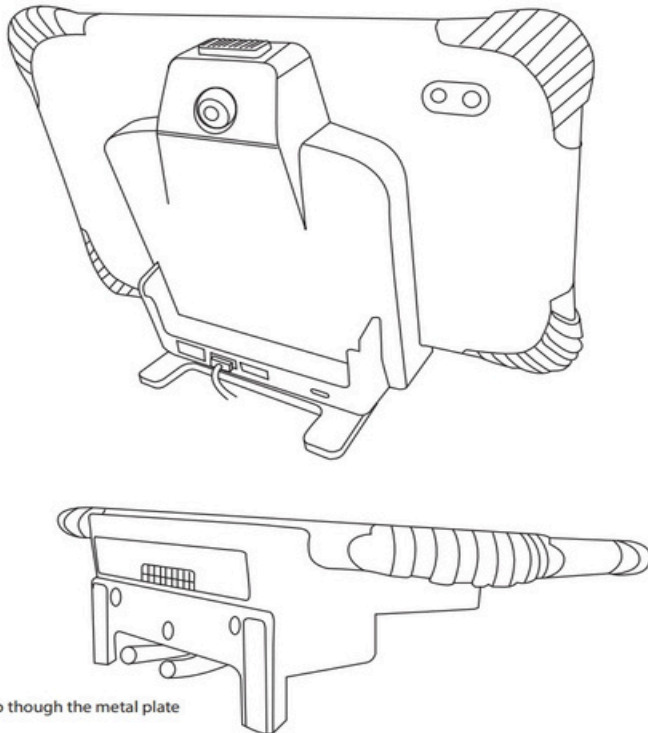

## 3. Fixed cable

When installing in the vehicle, please use below metal parts, it has 2 purposes.

1. Direct the cable toward the back side.
  2. It helps supporting the weight of the device. It will not shake even when the car has vibration.
- There are two options regarding installation. Please see video 2 below.

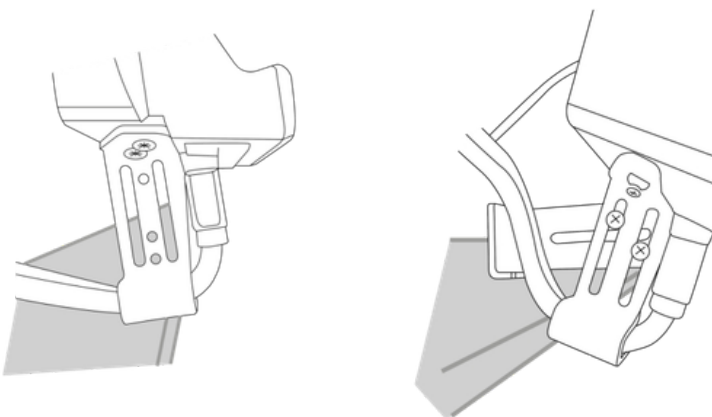

The length can be changed from 50mm to 80mm.

[https://drive.google.com/file/d/1ybp\\_Ji3AL1t94PQ\\_KVtJO9mk\\_J8UiY8Q/view?usp=sharing](https://drive.google.com/file/d/1ybp_Ji3AL1t94PQ_KVtJO9mk_J8UiY8Q/view?usp=sharing)

<https://drive.google.com/file/d/1etWxYVJcbXDs8J-GP0dq8IVuBiYc0t3S/view?usp=sharing>

## Chapter 5: Using Hardware Interface

### 5.1 Using Serial Port

1. RS232 purple/white wires are from CPU, it's same as MDT-860 and MDT-760. It can work even without an external power supply.
2. RS232 orange/yellow wires and RS485 blue/brown wires are converted from USB Hub and will only work if there is an external power supply.

Wirescolor	Definition	Devicettyports
White	RS232RXD(CPU)	/dev/user_external_tty
Purple	RS232TXD(CPU)	
Orange	RS232RXD(USB)	/dev/ttyUSB0
Yellow	RS232TXD(USB)	
Blue	RS485-A	/dev/ttyUSB1
Brown	RS485-B	

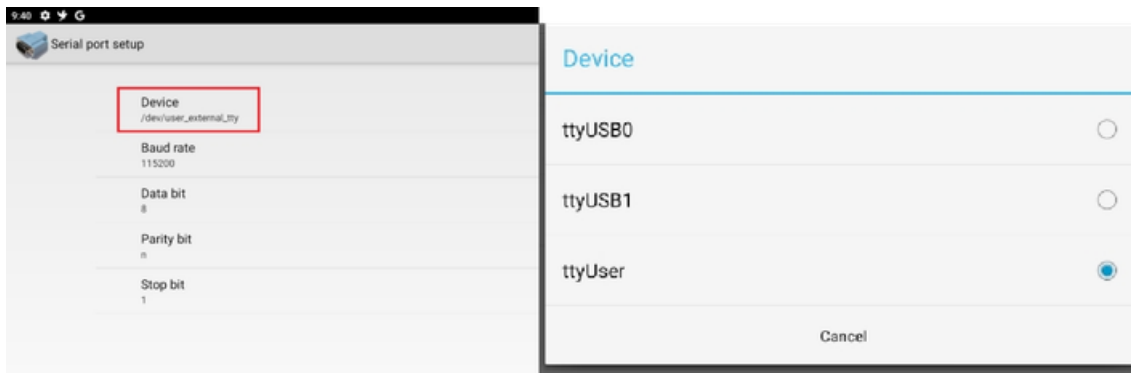

## 5.2 Using GPIO (only works on CRD805)

### 1. GPIO Tail Lines Instruction

Regarding the definition diagram of GPIO interface, please see the details in Chapter 1 "1.2 Cradle Cable definition".

### 2. GPIO\_DEMO Instruction

This software is only used for testing GPIO functions of device, and it isn't suitable for user's standard software.

- If the input 1 or input 2 is connected to a high power, key 1 or key 2 will display "true".
- Press set output button to open output, and press reset output button to close output.
- Press get adc button to read the input voltage.
- Press upgrade button to update the MCU firmware.

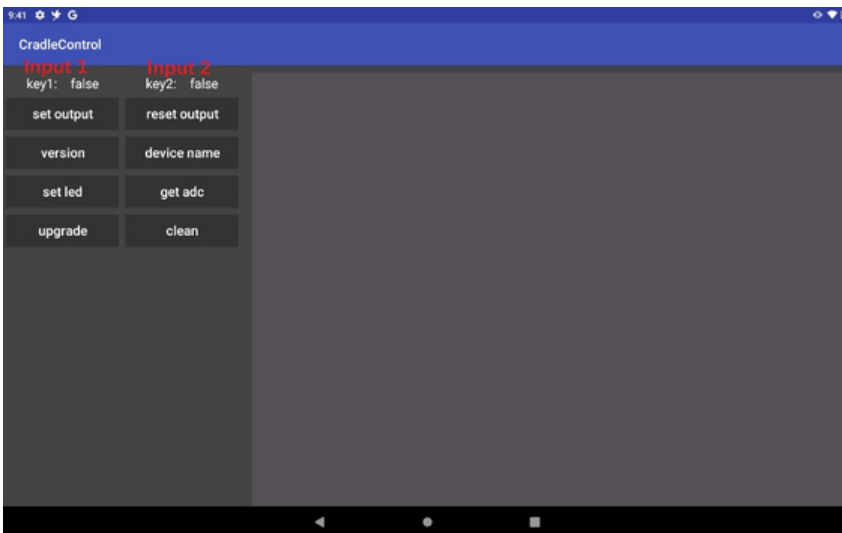

## 5.3 Using NFC Function

### 1. NFC Activation Method

Activate the NFC function in the settings.

Settings > Connection preferences > NFC > Enable Use NFC



## 2. NFC Usage Demo

Front access, easy for driver to login

After activating NFC function, place the NFC card close to the induction area.  
A prompt tone would be heard if the card is successfully identified.

MDT-805 NFC

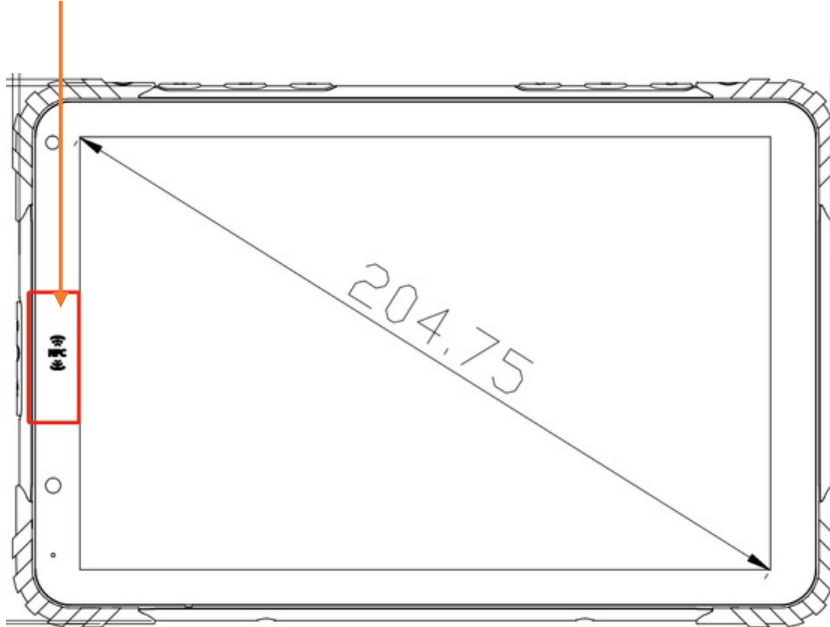

## 5.4 Using eSIM function

The MDT-805 has a built-in eSIM, but it cannot be used simultaneously with SIM 2. Only one can be used at a time.

1. Add eSIM profile (It can write approximately 3-5 eSIM profiles)

Go to the phone App > Dial **\*\*\*#8900\*\*\*** to access the eSIM App

Click "+" to add your eSIM profile.

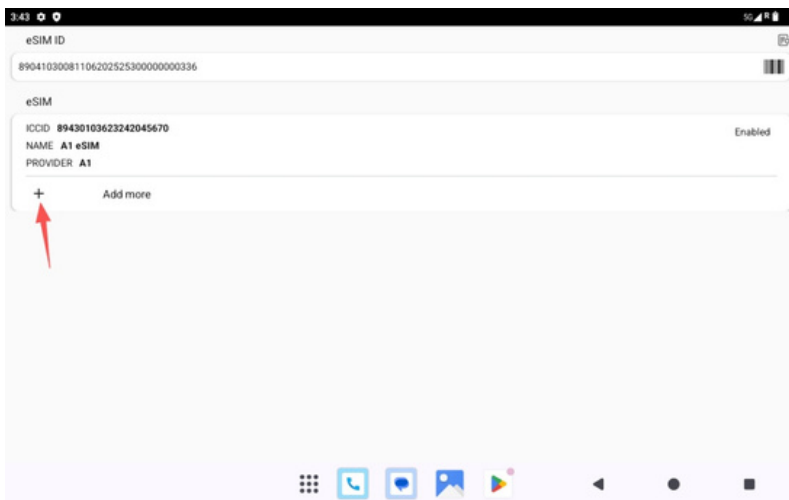

Two ways to add eSIM profile.

You can add an eSIM profile by scanning the operator's QR code or entering an activation code.

1) Add eSIM profile by scanning the QR code

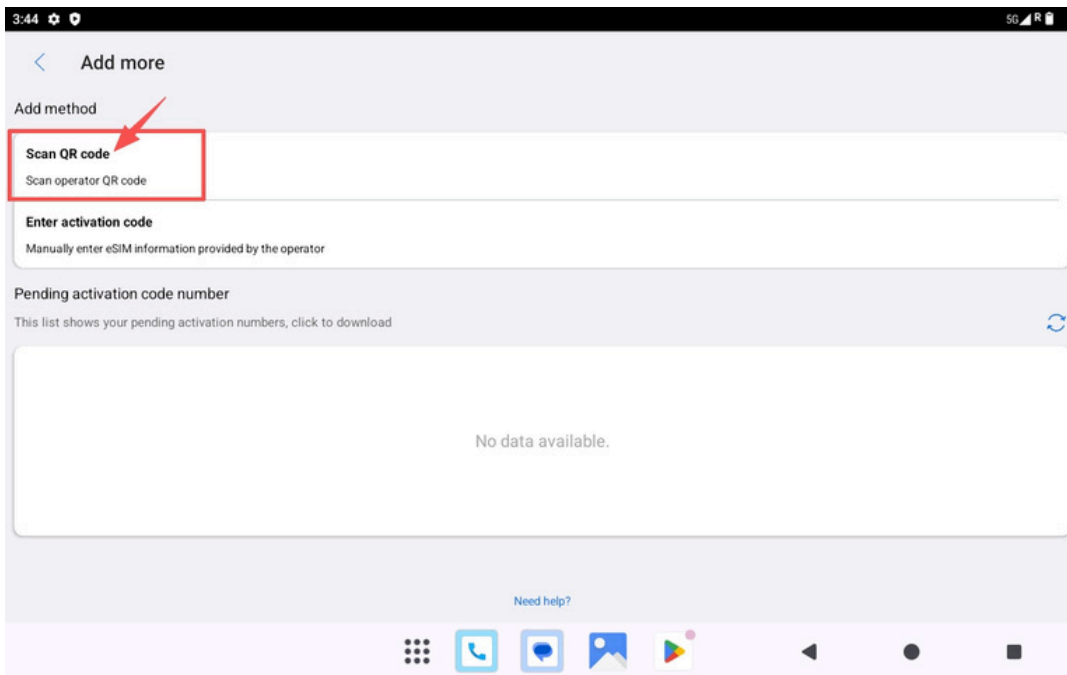

2) Add an eSIM profile by entering an activation code.

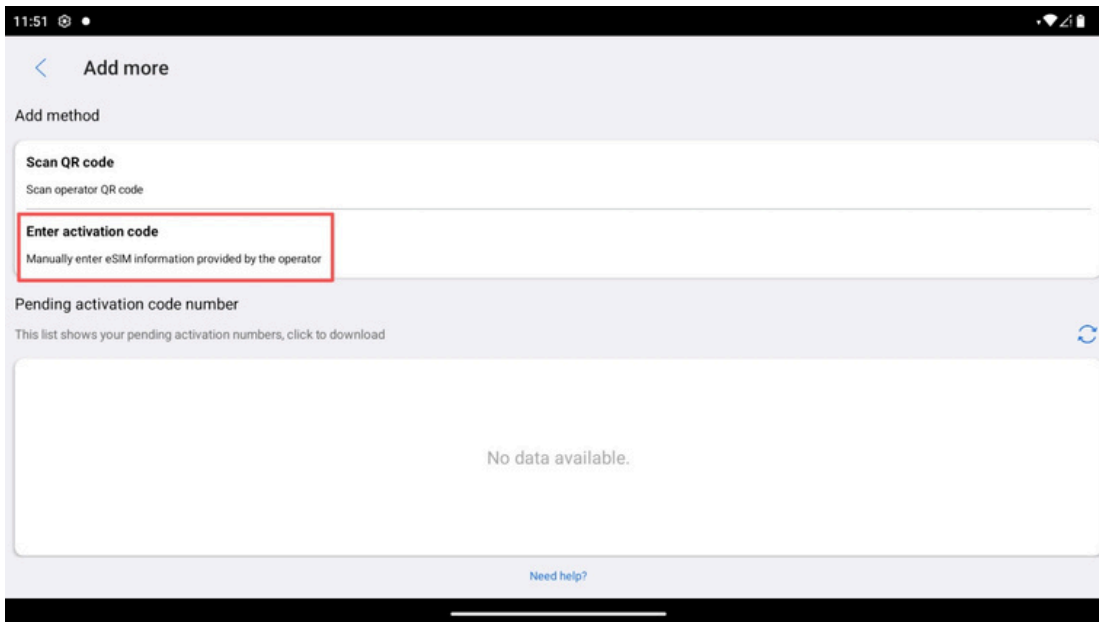

## Enter Activation code

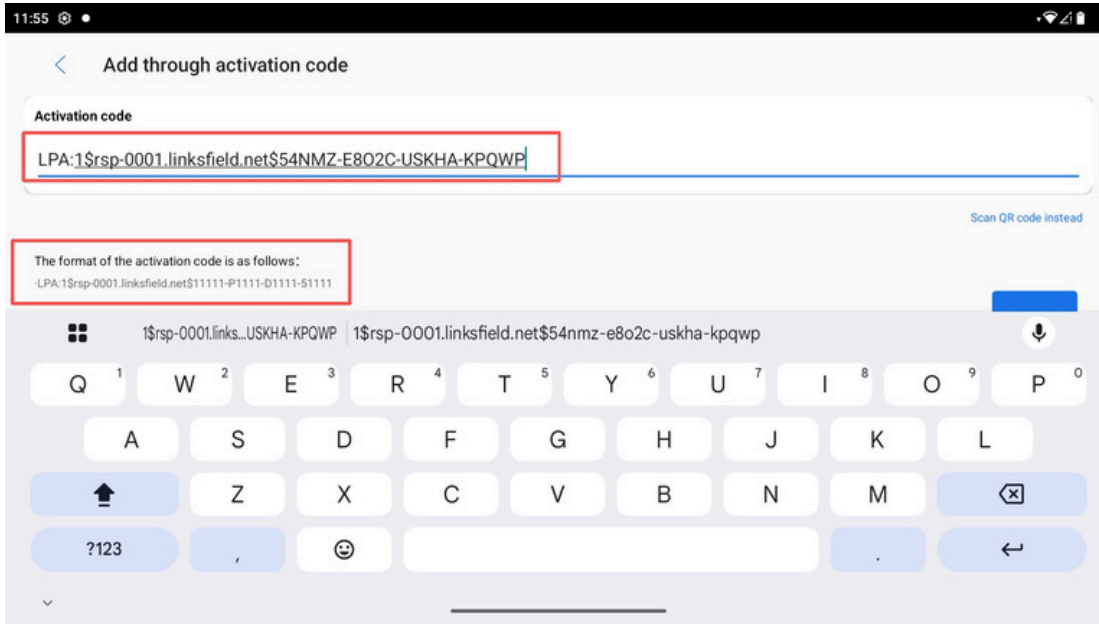

## 2. Erase eSIM profile

If you want to delete the written eSIM profile, you need to install the following APK to delete it.

Delete APK:

<https://drive.google.com/file/d/1obNkzSyKRfs0o4UD2v4h7Brn8X5B9jIT/view?usp=sharing>

- 1) Install apk (com.linksfield.android.euicc-v2.4.4-hide-with-delete.apk)
- 2) Dial \*##8900## to open the eSIM application
- 3) Disable the "Use SIM card" option
- 4) Erase SIM

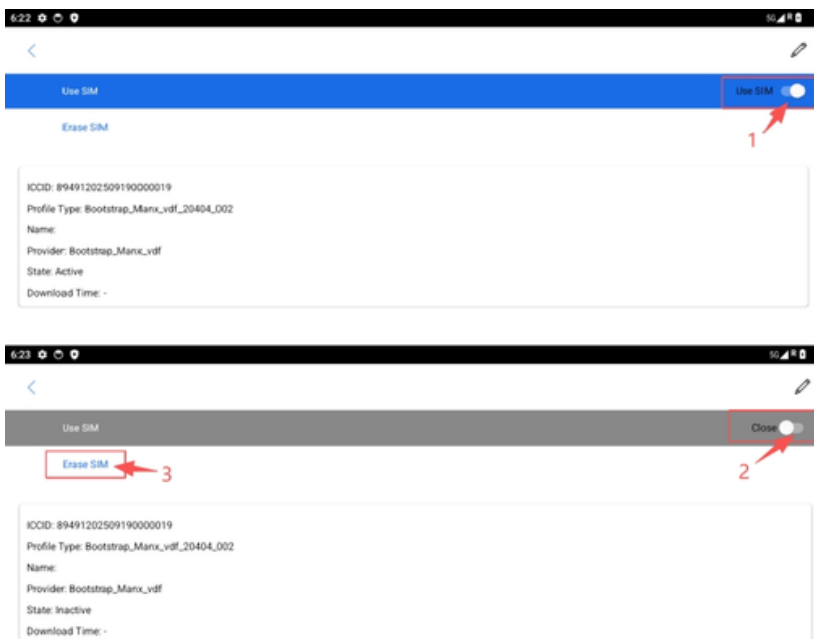

## Chapter 6: Software Support

### Demo application and source code available

We can provide demo applications such as reading ignition status, AVIN camera, Serial port, GPIO, barcode scanner and NFC etc. Please contact our Sales for details.

### Supplementary APIs

<https://www.paceblade.eu/web/content/955891>

Example source code and applications are provided.

#### Serial port access

#### Package installation

To install a package

To get the installation status through BroadcastReceiver

To delete a package

#### Power management

#### Cradle detection

#### Notification blocker

#### Additional IOs

Ignition signal

#### Programmatic firmware upgrade and configuration

Accepted image name patterns

Through image copy

From the command line

From application code

### Customization Services

PaceBlade's device management server is developed to allow customers to update different firmware and create a kiosk mode function:

- BOOT ANIMATION
- INSTALL APK
- ADD APN
- DEFAULT SETTING
- CUSTOMIZED BUTTON

For more details, please refer to Remote control server manual and Kiosk mode quick start guide.

[Remote control server manual](#)

[Kiosk mode quick start guide](#)

## Radio Parameters

Technical Characteristics of EUT	
<b>2G</b>	
Support Networks:	GSM, GPRS, EDGE
Support Bands:	GSM900, DCS1800
Frequency Range:	GSM900: Tx: 880-915MHz, Rx: 925-960MHz
	DCS1800: Tx: 1710-1785MHz, Rx: 1805-1880MHz
RF Output Power:	GSM900: 33.88dBm, GSM1800: 30.40dBm EDGE900: 22.86dBm, EDGE1800: 22.04dBm
Modulation Type:	GMSK, 8PSK
Type of Antenna:	FPC Antenna
Antenna Gain:	GSM900: -1.75dBi, DCS1800:-0.64dBi
GPRS/EDGE Class:	Class 12
<b>3G</b>	
Support Networks:	WCDMA, HSDPA, HSUPA
Support Bands:	WCDMA Band 1, WCDMA Band 8
Frequency Range:	WCDMA Band 1: Tx: 1920-1980MHz, Rx: 2110-2170MHz
	WCDMA Band 8: Tx: 880-915MHz, Rx: 925-960MHz
RF Output Power:	WCDMA Band 1: 22.14dBm, WCDMA Band 8: 23.01dBm
Modulation Type:	BPSK, QPSK, 16QAM
Antenna Type:	FPC Antenna
Antenna Gain:	WCDMA Band 1: 1.18dBi, WCDMA Band 8: -1.75dBi
<b>4G</b>	
Support Bands:	FDD-LTE Band1, 3, 7, 8, 20, 28, TDD-LTE Band 38, 40, 41
Frequency Range:	FDD-LTE Band 1: Tx: 1920-1980MHz, Rx: 2110-2170MHz
	FDD-LTE Band 3: Tx: 1710-1785MHz, Rx: 1805-1880MHz
	FDD-LTE Band 7: Tx: 2500-2570MHz, Rx: 2620-2690MHz
	FDD-LTE Band 8: Tx: 880-915MHz, Rx: 925-960MHz
	FDD-LTE Band 20: Tx: 832-862MHz, Rx: 791-821MHz
	FDD-LTE Band 28: Tx: 703-748MHz, Rx: 758-803MHz
	TDD-LTE Band 38: Tx: 2570-2620MHz, Rx: 2570-2620MHz
	TDD-LTE Band 40: Tx: 2300-2400MHz, Rx: 2300-2400MHz
TDD-LTE Band 41: Tx: 2496-2690MHz, Rx: 2496-2690MHz	
Max.RF Output Power:	FDD-LTE Band 1: 22.41dBm, FDD-LTE Band 3: 23.18dBm, FDD-LTE Band 7: 22.64dBm, FDD-LTE Band 8: 23.45dBm, FDD-LTE Band 20: 23.58dBm, FDD-LTE Band 28: 23.22dBm, TDD-LTE Band 38: 23.35dBm, TDD-LTE Band 40: 22.75dBm TDD-LTE Band 41: 23.06dBm
Modulation Type:	QPSK, 16QAM
Antenna Type:	FPC Antenna

Antenna Gain:	FDD-LTE Band 1: 1.18dBi, FDD-LTE Band 3: -0.64dBi, FDD-LTE Band 7: 1.04dBi, FDD-LTE Band 8: -1.75dBi, FDD-LTE Band 20: -1.85dBi, FDD-LTE Band 28: -3.81dBi, TDD-LTE Band 38: 1.3dBi, TDD-LTE Band 40: -1.53dBi, TDD-LTE Band 41: 1.3dBi,
<b>5G NR</b>	
SA Band:	N28, N38,
NSA Band:	N41, N78 /
Frequency Range:	N28: Tx: 703-748MHz, Rx: 758-803MHz
	N38: Tx: 2570-2620MHz, Rx: 2570-2620MHz
	N41: Tx: 2496-2690MHz, Rx: 2496-2690MHz
	N78: Tx: 3300-3800MHz, Rx: 3300-3800MHz
Modulation Type:	UL & DL up to 256QAM
Max.RF Output Power:	N28: 25.01dBm N38: 24.07dBm N41: 27.35dBm N78: 27.34dBm
Antenna Type:	FPC Antenna
Antenna Gain:	N28: -3.81dBi N38: 0.39dBi N41: 0.39dBi N78: 2.13dBi
<b>Bluetooth</b>	
Bluetooth Version:	Bluetooth V5.0
Frequency Range:	2402MHz-2480MHz
Max.RF Output Power:	3.76dBm (EIRP)
Type of Modulation:	GFSK, $\pi/4$ DQPSK, 8DPSK
Data Rate:	1Mbps, 2Mbps, 3Mbps
Quantity of Channels	79/40
Channel Separation:	1MHz/2MHz
Type of Antenna:	PIFA Antenna
Antenna Gain:	-1.07dBi
<b>Wi-Fi (2.4GHz)</b>	
Support Standards:	802.11b, 802.11g, 802.11n-HT20/40
Frequency Range:	2412-2472MHz for 802.11b/g/n(HT20) 2422-2462MHz for 802.11n(HT40)
Max.RF Output Power:	16.70dBm (EIRP)
Type of Modulation:	CCK, OFDM, QPSK, BPSK, 16QAM, 64QAM
Quantity of Channels	13 for 802.11b/g/n(HT20), 9 for 802.11n(HT40)
Channel Separation:	5MHz
Type of Antenna:	PIFA Antenna
Antenna Gain:	-1.07dBi
<b>NFC</b>	

Frequency Range:	13.56MHz
Radiated H-Field:	-2.90dBuA/m(@3m)
Modulation:	ASK
Type of Antenna:	FPC Antenna
Antenna Gain:	0dBi
Transmitter Product Class	1
Lora	
Frequency Range:	868.00MHz-868.6MHz 869.4MHz-869.650MHz
RF Output Power:	0.85dBm(ERP)
Type of Modulation:	FSK
Type of Antenna:	FPC Antenna
Antenna Gain:	2dBi
Receiver Categories:	2
GPS	
Frequency Range:	1575.42MHz Receiving 1176.45MHz Receiving

## Chapter 8: Safety and regulatory compliance

### Caution:

Use the Product in the environment with the temperature between -20°C and 60°C; Otherwise, it may damage your product. Products can only be used below 2000m altitude.

For the following equipment:

Brand Name: PaceBlade

Name: / Model No.: MDT-805

E-mail: sales@paceblade.eu

hereby declares that this product [PaceBlade MDT-805] is in compliance with the essential requirements and other relevant provisions of Directive 2014/53/EU.



The full text of the EU declaration of conformity is available at the following link:

[Admin\\_DoC\\_MDT880\\_RED.pdf](#)

The product shall only be connected to a USB interface of version USB2.0 and that the connection to a power USB is allowed.

Caution: Risk of hearing impairment. Prolonged exposure to high sound pressure levels from earphones or headphones can cause permanent hearing loss.



**CAUTION**  
**RISK OF EXPLOSION IF BATTERY IS REPLACED**  
**BY AN INCORRECT TYPE.**  
**DISPOSE OF USED BATTERIES ACCORDING**  
**TO THE INSTRUCTIONS**

Adapter shall be installed near the equipment and shall be easily accessible.

Only can use adapter as below:

PowerAdapter Model:GS-W20A0938C

Input: 100-240Va.c. 50/60Hz 0.6A Max

Output: 5Vd.c. 3A or 9Vd.c. 2.22A or 12Vd.c. 1.67A

Shenzhen Good-she technology Co., Ltd

This product is intended for sale and application in a business environment.

RED Article 10 2

-This product can be used across EU member states

RED Article 10 10

-The product is class 1 product, No restrictions

The RF distance between body and product is 0mm

## FCC RF Exposure Information and Statement

This device meets the government's requirements for exposure to radio waves. The guidelines are based on standards that were developed by independent scientific organizations through periodic and thorough evaluation of scientific studies. The standards include a substantial safety margin designed to assure the safety of all persons regardless of age or health. The SAR limit of USA (FCC) is 1.6 W/kg averaged. Device types: Tablet (FCC ID: 2AHAF-805) has also been tested against this SAR limit. SAR information can be viewed on-line at <http://www.fcc.gov/oet/ea/fccid/>. Please use the device FCC ID number for search. This device was tested simulation typical 0mm to body. To maintain compliance with FCC RF exposure requirements, the use of accessories should maintain a separation distance between the user's bodies mentioned above, the use of accessories should not contain metallic components in its assembly, the use of accessories that do not satisfy these requirements may not comply with FCC RF exposure requirements, and should be avoided.

This device has been tested and meets the IC RF exposure guidelines when used with an accessory designated for this product or when used with an accessory that contains no metal and that positions the handset a minimum of 0mm from the body. Noncompliance with the above restrictions may result in violation of RF exposure guidelines.

Cet appareil a été testé et répond aux directives d'exposition RF IC lorsqu'il est utilisé avec un accessoire désigné pour ce produit ou lorsqu'il est utilisé avec un accessoire qui ne contient pas de métal et qui positionne le téléphone à un minimum de 0 mm du corps. Le non-respect des restrictions ci-dessus peut entraîner une violation des lignes directrices relatives à l'exposition aux RF.

#### FCC Warning

This device complies with Part 15 of the FCC Rules. Operation is subject to the following two conditions:

(1) This device may not cause harmful interference, and (2) this device must accept any interference received, including interference that may cause undesired operation.

Note: This equipment has been tested and found to comply with the limits for a Class B digital device, pursuant to part 15 of the FCC Rules. These limits are designed to provide reasonable protection against harmful interference in a residential installation. This equipment generates, uses and can radiate radio frequency energy and, if not installed and used in accordance with the instructions, may cause harmful interference to radio communications. However, there is no guarantee that interference will not occur in a particular installation. If this equipment does cause harmful interference to radio or television reception, which can be determined by turning the equipment off and on, the user is encouraged to try to correct the interference by one or more of the following measures:

- Reorient or relocate the receiving antenna.
- Increase the separation between the equipment and receiver.
- Connect the equipment into an outlet on a circuit different from that to which the receiver is connected.
- Consult the dealer or an experienced radio/TV technician for help.

NOTE 2: Any changes or modifications to this unit not expressly approved by the party responsible for compliance could void the user's authority to operate the equipment.

#### IC WARNING

This device contains licence-exempt transmitter(s) that comply with Innovation, Science and Economic Development Canada's licence-exempt RSS(s). Operation is subject to the following two conditions:

- (1) This device may not cause interference.
- (2) This device must accept any interference, including interference that may cause undesired operation of the device.

L'émetteur/récepteur exempt de licence contenu dans le présent appareil est conforme aux CNR d'Innovation, Sciences et Développement économique Canada applicables aux appareils radio exempts de licence. L'exploitation est autorisée aux deux conditions suivantes:

1. L'appareil ne doit pas produire de brouillage;
2. L'appareil doit accepter tout brouillage radioélectrique subi, même si le brouillage est susceptible d'en compromettre le fonctionnement.